

Nov. 2008



# SERVICE MANUAL ADDENDUM

---

## IC-F110S IC-F111S IC-F121S

---

### CONTENTS

REPLACEMENT PAGE ..... 5-5

### 5-3 SOFTWARE ADJUSTMENT

Select an operation using [↑] / [↓] keys, then set specified value using [←] / [→] keys on the connected computer keyboard.

ADJUSTMENT	ADJUSTMENT CONDITION	MEASUREMENT		VALUE
		UNIT	LOCATION	
REFERENCE FREQUENCY [TXF]	1 <ul style="list-style-type: none"> <li>• Operating freq. : 173.900 MHz</li> <li>• Output power : Low1</li> <li>• Connect the RF power meter or 50 Ω dummy load to the antenna connector.</li> <li>• Transmitting</li> </ul>	Rear panel	Loosely couple a frequency counter to the antenna connector.	173.9000 MHz
OUTPUT POWER [Power (Hi)]	1 <ul style="list-style-type: none"> <li>• Operating freq.: 155.000 MHz (25 W ver.) 173.900 MHz (50 W ver.)</li> <li>• Output power : High</li> <li>• Transmitting</li> </ul>	Rear panel	Connect an RF power meter to the antenna connector.	25.0 W (25 W ver.) 50.0 W (50 W ver.)
[Power (L2)]	2 <ul style="list-style-type: none"> <li>• Output power : Low2</li> <li>• Transmitting</li> </ul>			10.0 W (25 W ver.) 25.0 W (50 W ver.)
[Power (L1)]	3 <ul style="list-style-type: none"> <li>• Output power : Low1</li> <li>• Transmitting</li> </ul>			2.5 W (25 W ver.) 5.0 W (50 W ver.)
FM DEVIATION [MOD W]	1 <ul style="list-style-type: none"> <li>• Operating freq. : 155.000 MHz</li> <li>• Output power : Low1</li> <li>• IF bandwidth : Wide</li> <li>• Connect an audio generator to the [MIC] jack through the JIG cable and set as: 1.0 kHz/40 mVrms</li> <li>• Set an FM deviation meter as: HPF : OFF LPF : 20 kHz De-emphasis: OFF Detector : (P-P)/2</li> <li>• Transmitting</li> </ul>	Rear panel	Connect an FM deviation meter to the antenna connector through the attenuator.	±4.1 kHz [N/W] ±3.3 kHz [N/M]
[MOD Ratio]	2 <ul style="list-style-type: none"> <li>• IF bandwidth : Narrow</li> <li>• Transmitting</li> </ul>			±2.1 kHz
MODULATION BALLANCE [BAL W]	1 <ul style="list-style-type: none"> <li>• Set to the DTCS set channel, and push [Connect] on the Adjustment software.</li> <li>• Operating freq. : 155.000 MHz</li> <li>• Output power : Low1</li> <li>• Transmitting</li> </ul>	Rear panel	Connect an FM deviation meter with an oscilloscope to the antenna connector through an attenuator.	Set to square wave form 
[BAL Ratio]	2 <ul style="list-style-type: none"> <li>• IF bandwidth : Narrow</li> <li>• Transmitting</li> </ul>			
CTCSS/DTCS DEVIATION [CTCS/DTCS]	1 <ul style="list-style-type: none"> <li>• Operating freq. : 155.000 MHz</li> <li>• Output power : Low1</li> <li>• IF bandwidth : Wide</li> <li>• CTCSS : 151.4 Hz</li> <li>• DTCS code : 007</li> <li>• Set the FM deviation meter as: HPF : OFF LPF : 20 kHz De-emphasis: OFF Detector : (P-P)/2</li> <li>• No audio applied to the [MIC] connector.</li> <li>• Transmitting</li> </ul>	Rear panel	Connect an FM deviation meter to the antenna connector through the attenuator.	±0.56 kHz [EUR-45] ±0.65 kHz [RUS-02] ±0.7 kHz [Others]

May. 2008



# SERVICE MANUAL ADDENDUM

---

## IC-F110S IC-F111S IC-F121S

---

### CONTENTS

PARTS LIST .....	1
MECHANICAL PARTS .....	7
BOARD LAYOUTS .....	8
VOLTAGE DIAGRAM .....	10







[MAIN UNIT]

Table with columns: REF NO., ORDER NO., DESCRIPTION, M., H/V LOCATION. Lists various electrical components and their specifications.

[MAIN UNIT]

Table with columns: REF NO., ORDER NO., DESCRIPTION, M., H/V LOCATION. Lists various electrical components and their specifications.

M.=Mounted side (T: Mounted on the Top side, B: Mounted on the Bottom side) S.=Surface mount





[MAIN UNIT]

REF NO.	ORDER NO.	DESCRIPTION	M.	H/V LOCATION
C367	4030011600	S.CER C1608 JB 1E 104K-T	T	51.7/31.1
C368	4030007130	S.CER C1608 CH 1H 101J-T	T	82.7/11
C370	4030007130	S.CER C1608 CH 1H 101J-T	T	115/23.4
C375	4030006860	S.CER C1608 JB 1H 102K-T	B	37.6/52.2
C376	4030006860	S.CER C1608 CH 1H 0R3B-T	B	37.6/52.2
C390	4030011170	S.CER GRM31M2C2H180JV01L	T	20.5/57.7
C392	4030011120	S.CER GRM31M2C2H100JV01L	T	31/63.9
C393	4030011120	S.CER GRM31M2C2H100JV01L	T	39.2/66.6
C401	4030011340	S.CER C1608 CH 1H 471J-T	T	79.2/67.8
C402	4030011340	S.CER C1608 CH 1H 471J-T	T	60.3/67.7
C405	4030006860	S.CER C1608 JB 1H 102K-T	B	77.9/59.2
C406	4030011340	S.CER C1608 CH 1H 471J-T	B	79.2/59.2
C407	4030007090	S.CER C1608 CH 1H 470J-T	B	80.5/59.2
C408	4030006860	S.CER C1608 JB 1H 102K-T	T	123.7/67.7
C409	4030007090	S.CER C1608 CH 1H 470J-T	B	91.1/52.2
C410	4030007090	S.CER C1608 CH 1H 470J-T	B	96.9/67.6
C411	4030011340	S.CER C1608 CH 1H 471J-T	B	96.9/66.2
C412	4030006860	S.CER C1608 JB 1H 102K-T	B	96.9/64.8
C413	4030011340	S.CER C1608 CH 1H 471J-T	B	105.8/61
C424	4030007130	S.CER C1608 CH 1H 101J-T	T	133.1/66.4
C426	4030007130	S.CER C1608 CH 1H 101J-T	T	123.7/69
C427	4030007170	S.CER C1608 CH 1H 221J-T	B	122/5.7
C428	4030007130	S.CER C1608 CH 1H 101J-T	T	115/26
C429	4030010240	S.CER C1608 JB 1H 391K-T	B	96.5/50.8
C430	4030006860	S.CER C1608 JB 1H 102K-T	B	115.9/17.2
C431	4030007130	S.CER C1608 CH 1H 101J-T	B	109.7/61
C432	4030007130	S.CER C1608 CH 1H 101J-T	T	112.4/18.5
C433	4030007130	S.CER C1608 CH 1H 101J-T	T	117.2/5.5
C508	4030011170	S.CER GRM31M2C2H180JV01L		
C509	4030011600	S.CER C1608 JB 1E 104K-T		
C510	4030007040	S.CER C1608 CH 1H 180J-T		
J1	6510018430	S.CNR AXN330C038P	T	23/8.3
J2	6510022470	S.CNR 40FLT-SM1-TB	T	67.5/10.6
J4	6450000140	CNR HSJ0807-01-010		
J6	6510019251	S.CNR B11B-ZR-SM4-TF (LF) (SN)	T	120.7/16
J7	6510014961	S.CNR B2B-ZR-SM4-TF (LF) (SN)	T	130.5/25.5
W1	7120000470	JMP ERDS2T0		
W2	8900011862	CBL OPC-1195B <TJM>		
W4	7030003860	S.RES ERJ3GE JPW V	T	96.3/24.3
W5	7030003860	S.RES ERJ3GE JPW V	B	89.4/20.8
EP1	6910013370	S.BEA BLM18BB221SN1D	B	95.8/29.9
EP2	6910011560	BEA HF70BB4.5X5X1.6		
EP3	6910011560	BEA HF70BB4.5X5X1.6		
EP4	6910010280	BEA HF70BB9.5X10.4X4.9		
EP5	6910010280	BEA HF70BB9.5X10.4X4.9		

M.=Mounted side (T: Mounted on the Top side, B: Mounted on the Bottom side)  
S.=Surface mount

# BOARD LAYOUTS

The combination of this side and the bottom side shows the board layout in the same configuration as the actual P.C.Board.

## • MAIN UNIT (TOP VIEW)

## • FRONT UNIT (TOP VIEW)

1	8V	AFO	MICE	GND
2	CLO	PTT	MIC	CLI
7				
8				

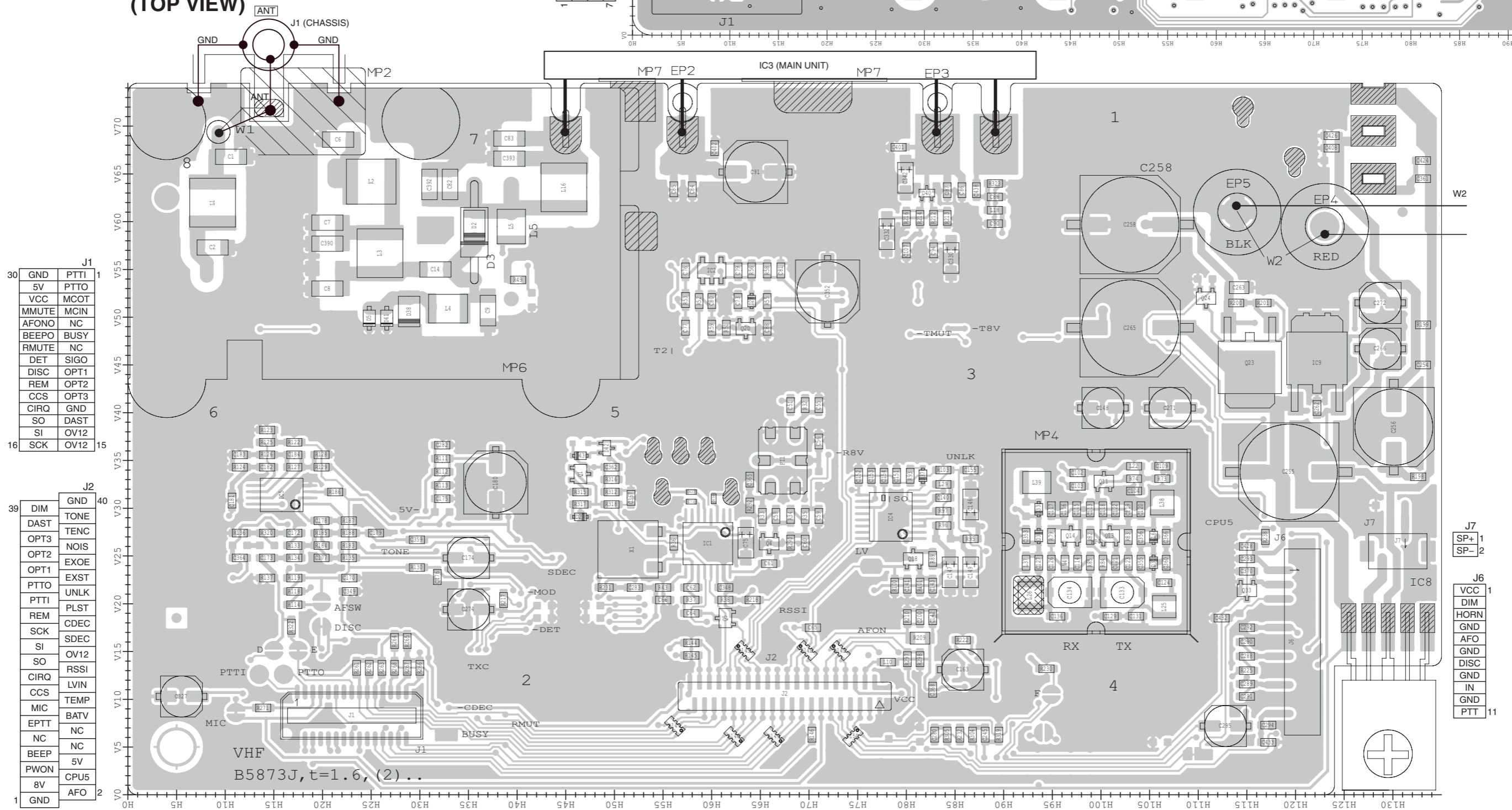
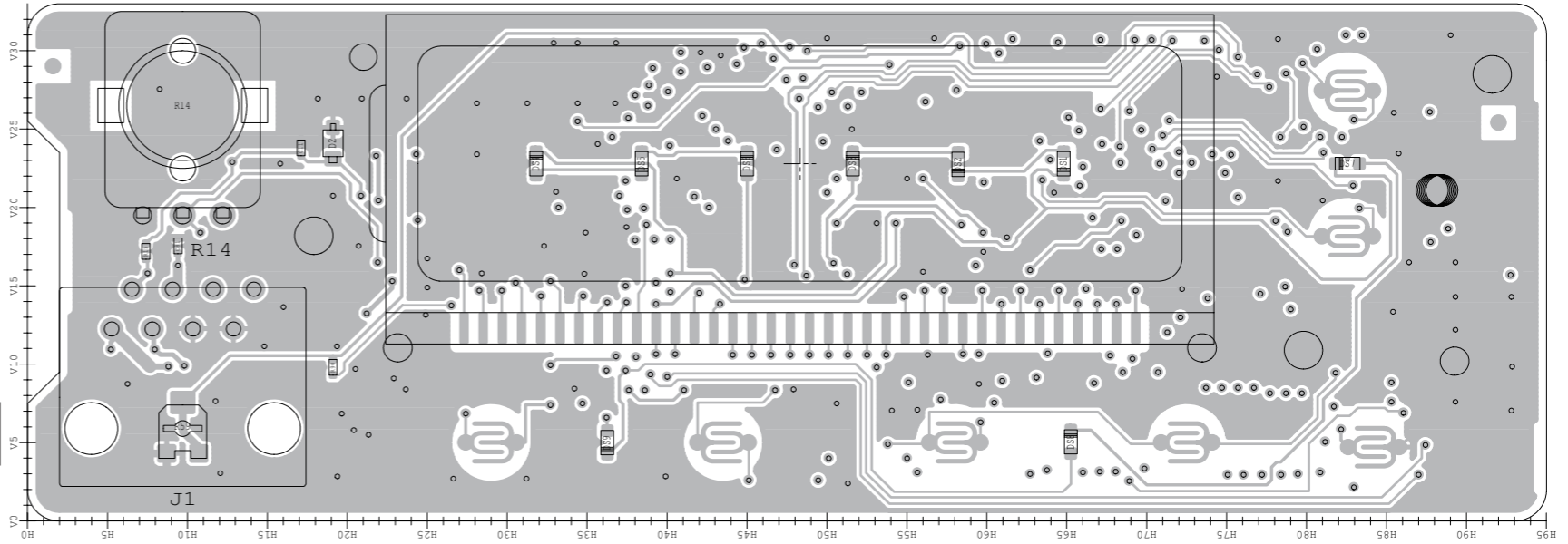

1	GND	PTTI
2	5V	PTTO
3	VCC	MCOT
4	MMUTE	MCIN
5	AFONO	NC
6	BEEPO	BUSY
7	RMUTE	NC
8	DET	SIGO
9	DISC	OPT1
10	REM	OPT2
11	CCS	OPT3
12	CIRQ	GND
13	SO	DAST
14	SI	OV12
15	SCK	OV12

1	DIM	GND
2	DAST	tone
3	OPT3	TENC
4	OPT2	NOIS
5	OPT1	EXOE
6	PTTO	EXST
7	PTTI	UNLK
8	REM	PLST
9	SCK	CDEC
10	SI	SDEC
11	SO	OV12
12	CIRQ	RSSI
13	CCS	LVIN
14	MIC	TEMP
15	EPTT	BATV
16	NC	NC
17	BEEP	NC
18	PWON	5V
19	8V	CPU5
20	GND	AFO

1	SP+
2	SP-

1	VCC
2	DIM
3	HORN
4	GND
5	AFO
6	GND
7	DISC
8	GND
9	IN
10	GND
11	PTT

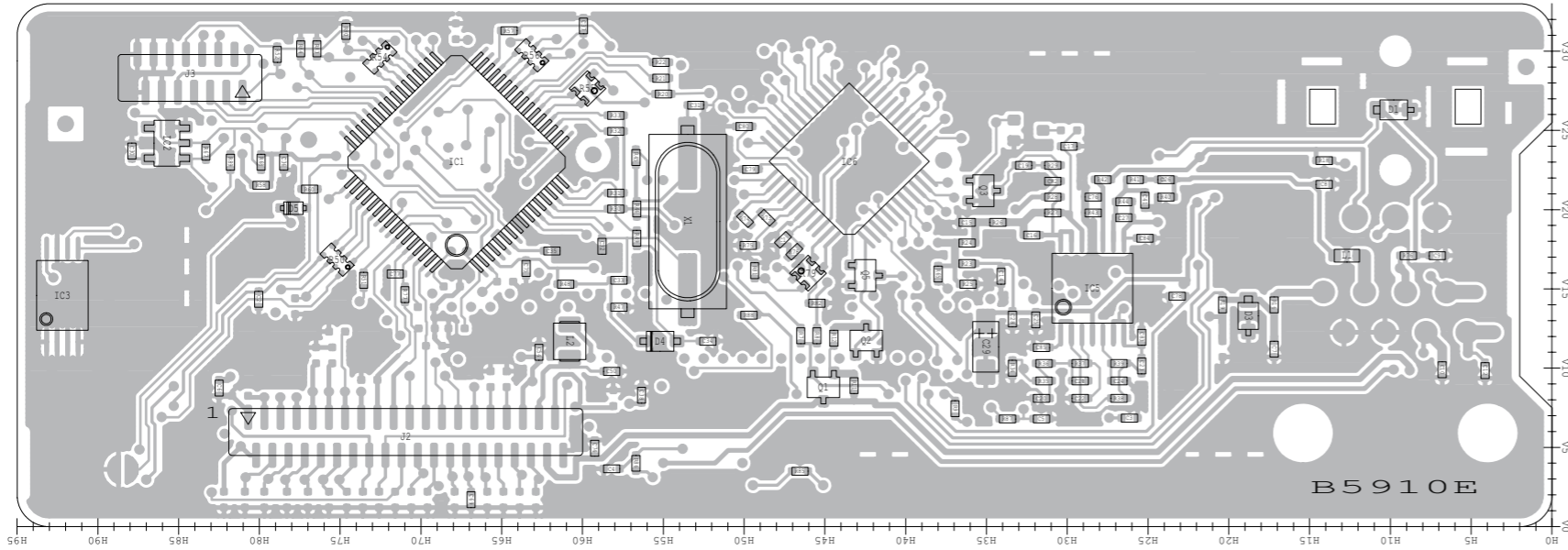

• FRONT UNIT  
(BOTTOM VIEW)

The combination of this side and the bottom side shows the board layout in the same configuration as the actual P.C.Board.

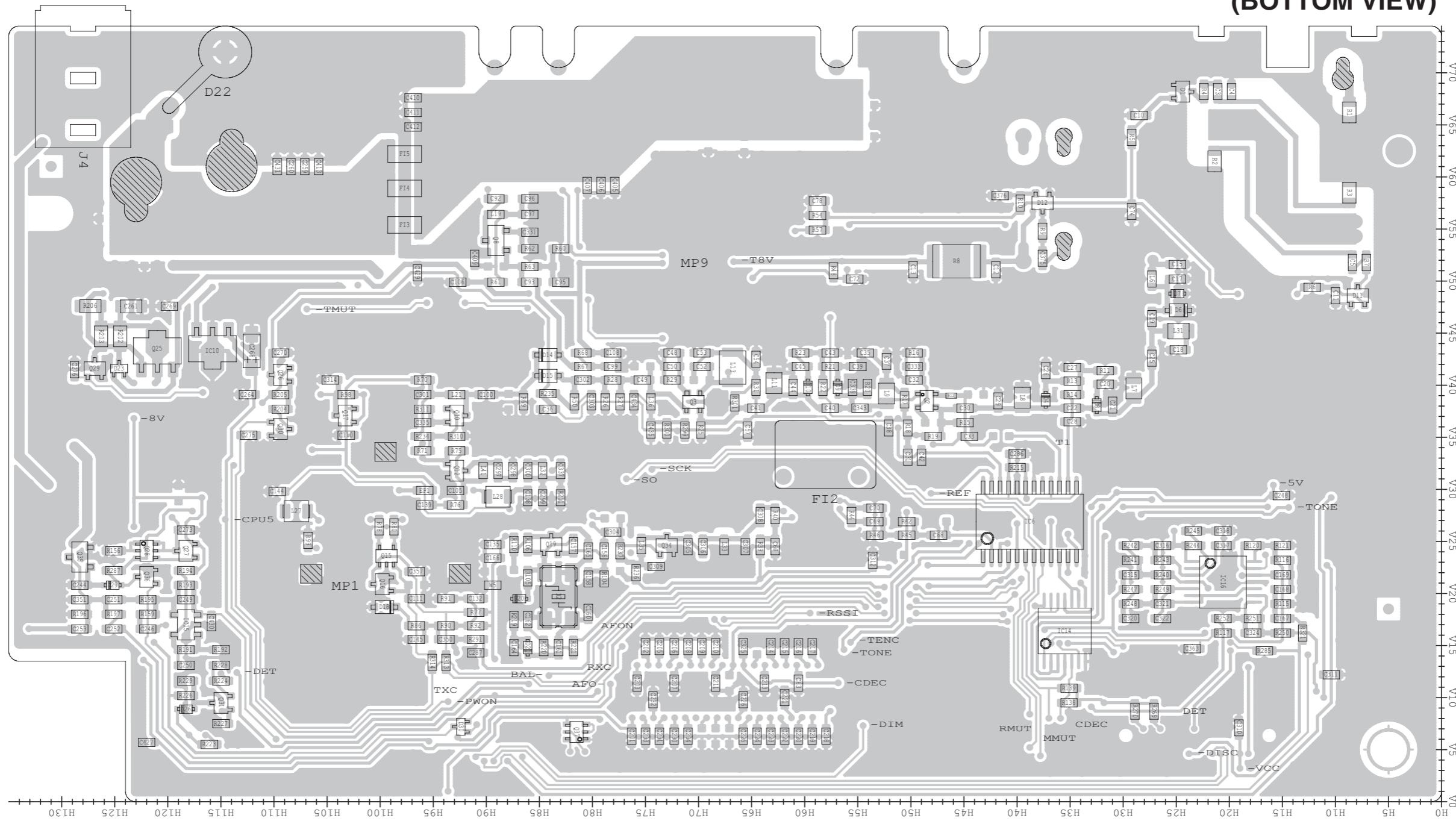

• MAIN UNIT  
(BOTTOM VIEW)

# VOLTAGE DIAGRAM

## FRONT UNIT

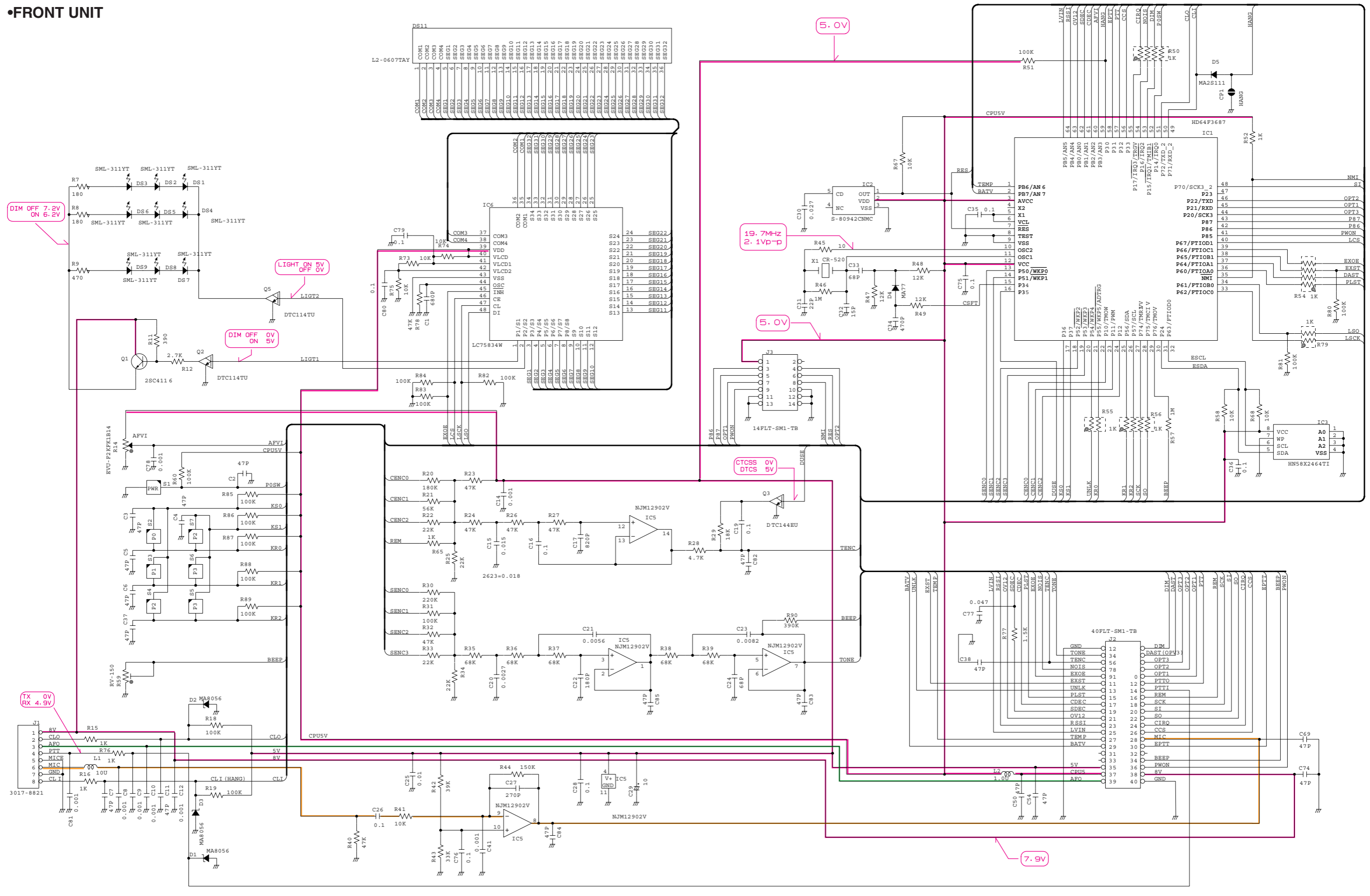

•MAIN UNIT

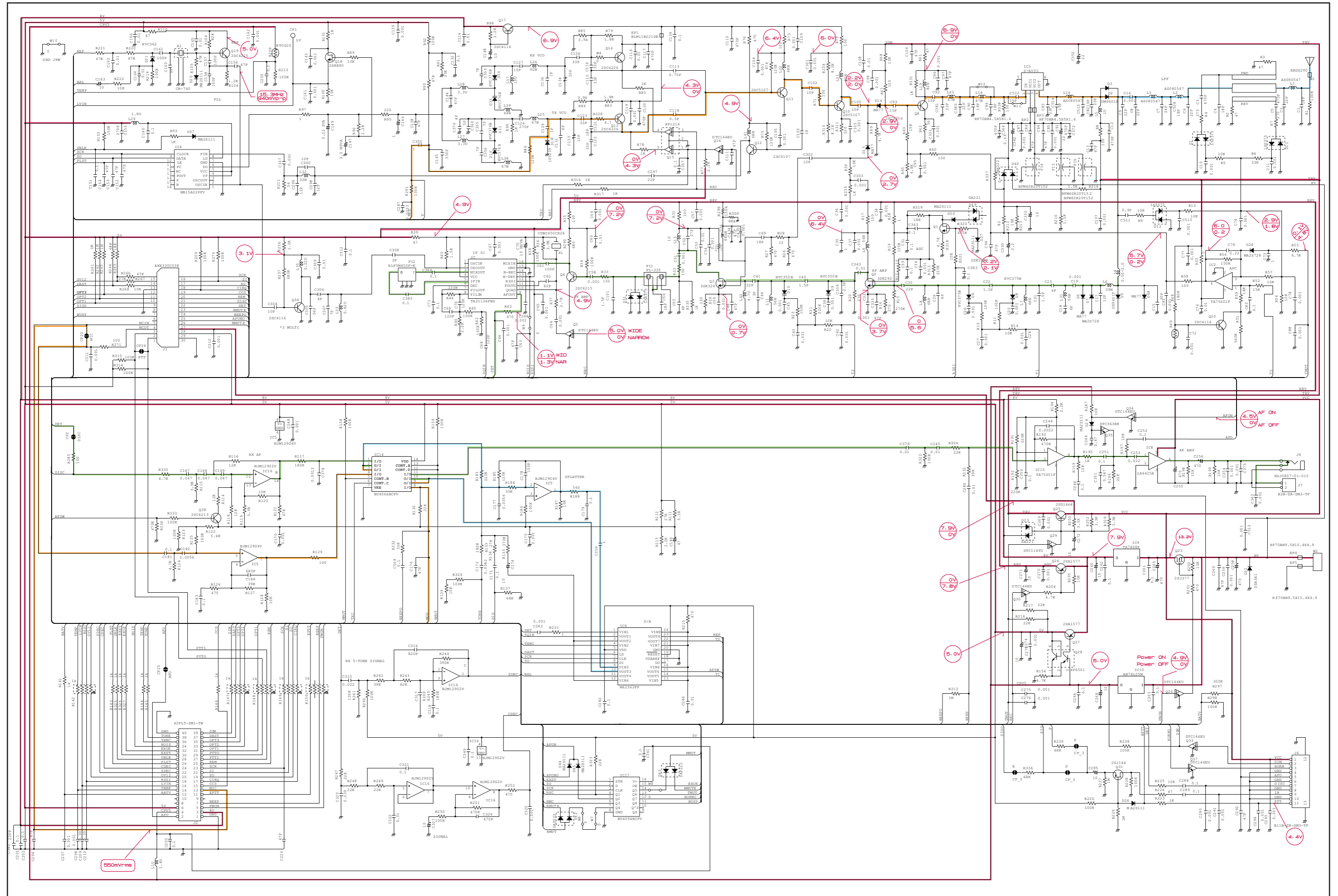

Jul. 2007



# SERVICE MANUAL ADDENDUM

---

## IC-F110S IC-F111S IC-F121S

---

### CONTENTS

PARTS LIST .....	1
MECHANICAL PARTS .....	7
BOARD LAYOUTS .....	8
VOLTAGE DIAGRAM .....	10



[MAIN UNIT]

Table with columns: REF NO., ORDER NO., DESCRIPTION, M., H/V LOCATION. Contains parts list for a MAIN UNIT including IC1-IC17, Q1-Q38, D1-D12, and F11-F14.

[MAIN UNIT]

Table with columns: REF NO., ORDER NO., DESCRIPTION, M., H/V LOCATION. Contains parts list for a MAIN UNIT including F15, X1, X2, L1-L25, L26-L38, R1-R20, R21-R45.

M.=Mounted side (T: Mounted on the Top side, B: Mounted on the Bottom side) S.=Surface mount









**[MAIN UNIT]**

REF NO.	ORDER NO.	DESCRIPTION	M.	H/V LOCATION
W11	7030003860	S.RES ERJ3GE JPW V [USA-02], [GEN-02]		
W12	7030003860	S.RES ERJ3GE JPW V [USA-02], [GEN-02] only		
EP1	6910013370	S.BEA BLM18BB221SN1D	B	95.8/29.9
EP2	6910011560	BEA HF70BB4.5X5X1.6		
EP3	6910011560	BEA HF70BB4.5X5X1.6		
EP4	6910010280	BEA HF70BB9.5X10.4X4.9		
EP5	6910010280	BEA HF70BB9.5X10.4X4.9		

M.=Mounted side (T: Mounted on the Top side, B: Mounted on the Bottom side)  
S.=Surface mount

# MECHANICAL PARTS

## [CHASSIS PARTS]

REF NO.	ORDER NO.	DESCRIPTION	QTY.
J1	6510004880	MR-DSE-01	1
MP1	8010019064	2601 CHASSIS-4 [EUR-02], [EUR-42], [GEN-02]	1
	8010019134	2601 LONG CHASSIS-4 [USA-02], [GEN-02]	1
MP2	8110007821	2601 COVER-1	1
MP3	8810008661	Screw BT B0 3X8 NI-ZC3 (BT)	8
MP4	8810008661	Screw BT B0 3X8 NI-ZC3 (BT)	2
MP5	8810008661	Screw BT B0 3X8 NI-ZC3 (BT)	2
MP6	8810008661	Screw BT B0 3X8 NI-ZC3 (BT)	1
MP7	8810009991	Screw BT B0 3X8 NI-ZK3 (BT)	4
MP8	8810009991	Screw BT B0 3X8 NI-ZK3 (BT)	2
MP10	8930058990	Shield sponge (V) [EUR-02], [EUR-42] only	1

## [FRONT UNIT]

REF NO.	ORDER NO.	DESCRIPTION	QTY.
J1	6450002210	3017-8821	1
J2*	6510022471	40FLT-SM2-TB (LF) (SN)	1
SP1	2510001221	C052SB500-14	1
W1	8900010503	OPC-1046B-1	1
W2	8900011800	OPC-1199	1
MP1	8210019080	2601 FRONT PANEL (Incl. MP9)	1
MP2	8930058340	2601 FRONT KEY	1
MP3	8310054410	2601 FRONT PLATE	1
MP4	8210019090	2601 REFLECTOR	1
MP5	8610011180	Knob N-292 (Incl. MP6)	1
MP7	8810008661	Screw BT B0 3X8 NI-ZC3 (BT)	2
MP8	8510014930	2601 EARTH PLATE	1
MP10	8810008661	Screw BT B0 3X8 NI-ZC3 (BT)	2

## [MAIN UNIT]

REF NO.	ORDER NO.	DESCRIPTION	QTY.
J1*	6510018430	AXN330C038	1
J2*	6510022471	40FLT-SM2-TB (LF) (SN)	1
J4	6450000140	HSJ0807-01-010	1
J6*	6510019251	B11B-ZR-SM4-TF (LF) (SN)	1
J7*	6510014961	B2B-ZR-SM4-TF (LF) (SN)	1
W1	7120000470	ERDS2T0	1
W2	8900011862	OPC-1195B	1
EP2	6910011560	HF70BB4.5X5X1.6	1
EP3	6910011560	HF70BB4.5X5X1.6	1
EP4	6910010280	HF70BB9.5X10.4X4.9	1
EP5	6910010280	HF70BB9.5X10.4X4.9	1
MP1	8510002280	VCOSheild plate (A) (FX-15)	1
MP2	8930058840	Shield sponge (T) [EUR-02], [EUR-42], [GEN-02] only	1
		Shield sponge (T) [GEN-02], [USA-02], [GEN-02] only	1
MP3	8930058840	Shield sponge (T) [EUR-02], [EUR-42], [GEN-02] only	1
MP4*	8510014940	2601 VCO CASE	1
MP5	8510014950	2601 VCO COVER	1
MP6	8510014910	2601 FILTER CASE	1
MP7	8510015110	2602 M-PLATE	1
MP10	8930059380	Shield sponge (X) [EUR-02], [EUR-42] only	1
MP11	8930061830	THERMALLY SHEET (AN) [USA-02], [GEN-02] only	1

\*: Refer to SECTION 9 "BOARD LAYOUTS."

†: Optional product

## [ACCESSORIES]

REF NO.	ORDER NO.	DESCRIPTION	QTY.
MC1†	-	HM-152	1
W1†	-	OPC-1194A [EUR-02], [EUR-42], [GEN-02]	1
	-	OPC-1132A [USA-02], [GEN-02]	1
W2†	-	OPC-049A	1
MP1	8010019151	2601 MOBIL BRACKET-1	1
MP2	8930059160	2601 FELT	2
MP3	8820000530	Flange bolt M4X8 NI	4
MP4	8810000471	Screw PH (+-) M5X12 ZC3	4
MP5	8810005841	Screw BT A0 5X20 ZC3	4
MP6	8850000150	Flat washer M5 BS NI	4
MP7	8850000391	SPRING WASHER M5 ZC3	4
MP8	8830000121	Nut M5 ZC3	4
MP9	8950005110	2289 MIC HANGER	1
MP10	8310054770	1705 LCD SEAL (F)	1
MP11	8810004700	Screw BT A0 3X16 SUS	2

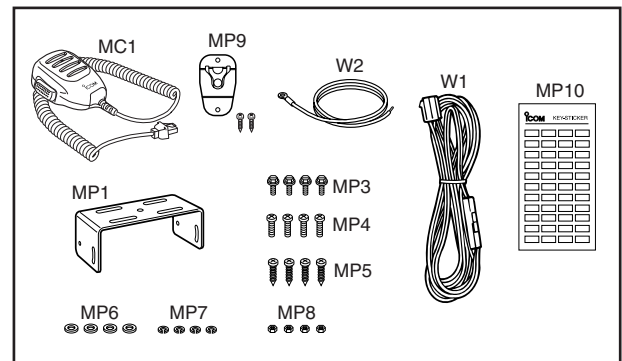

# BOARD LAYOUTS

The combination of this side and the bottom side shows the board layout in the same configuration as the actual P.C.Board.

## • MAIN UNIT (TOP VIEW)

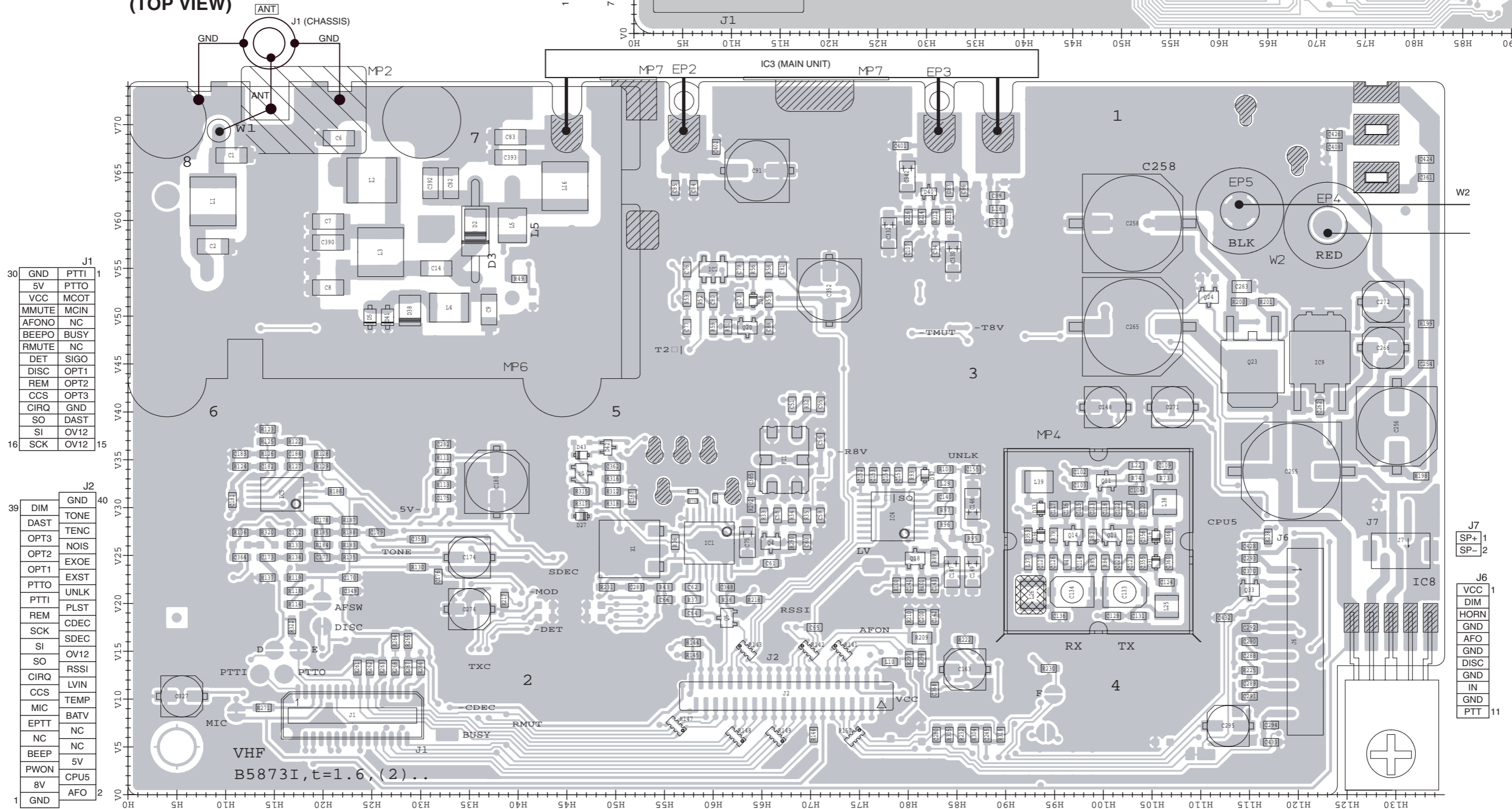

## • FRONT UNIT (TOP VIEW)

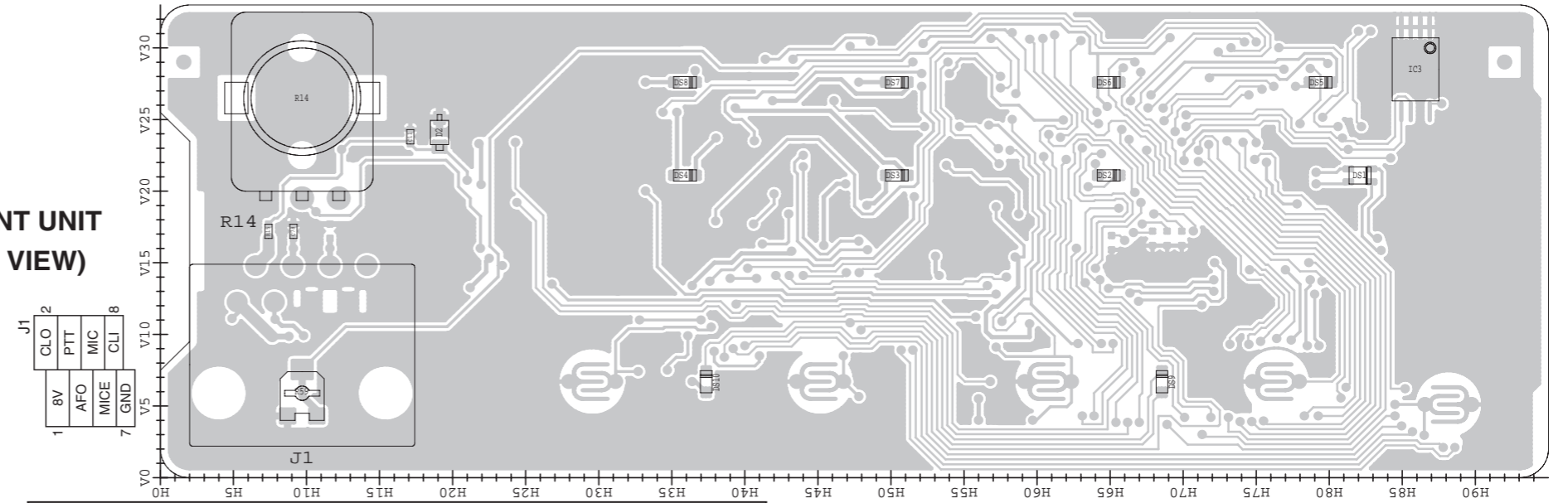

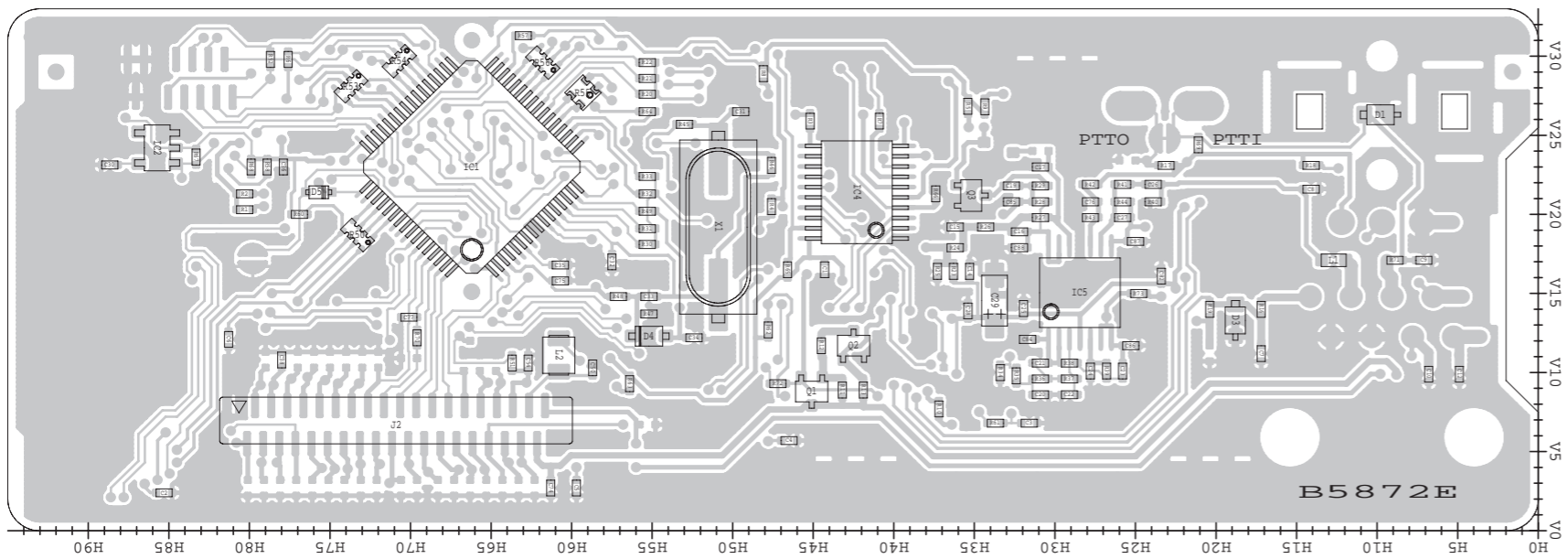

• FRONT UNIT  
(BOTTOM VIEW)

The combination of this side and the bottom side shows the board layout in the same configuration as the actual P.C.Board.

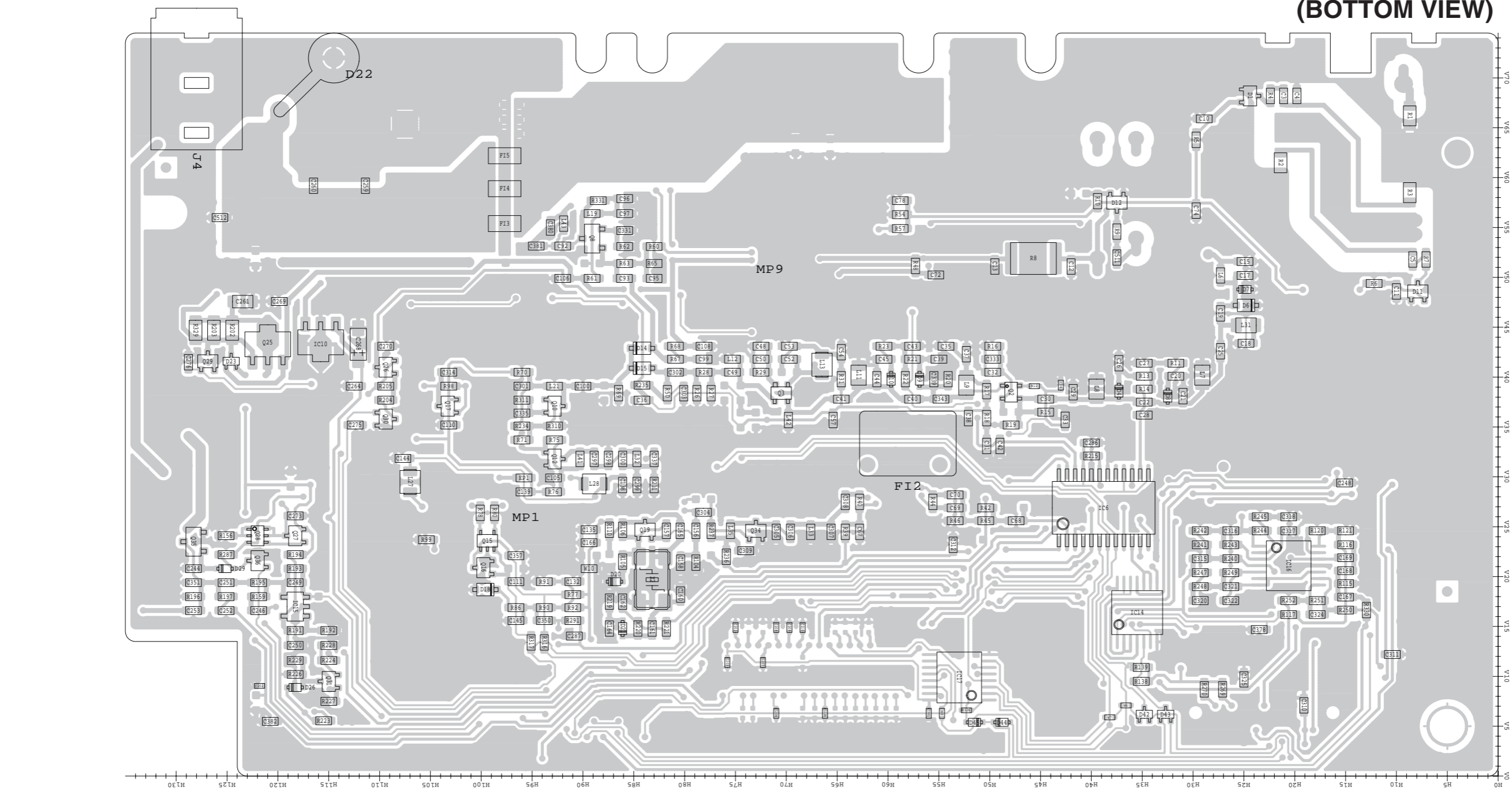

• MAIN UNIT  
(BOTTOM VIEW)

# VOLTAGE DIAGRAM

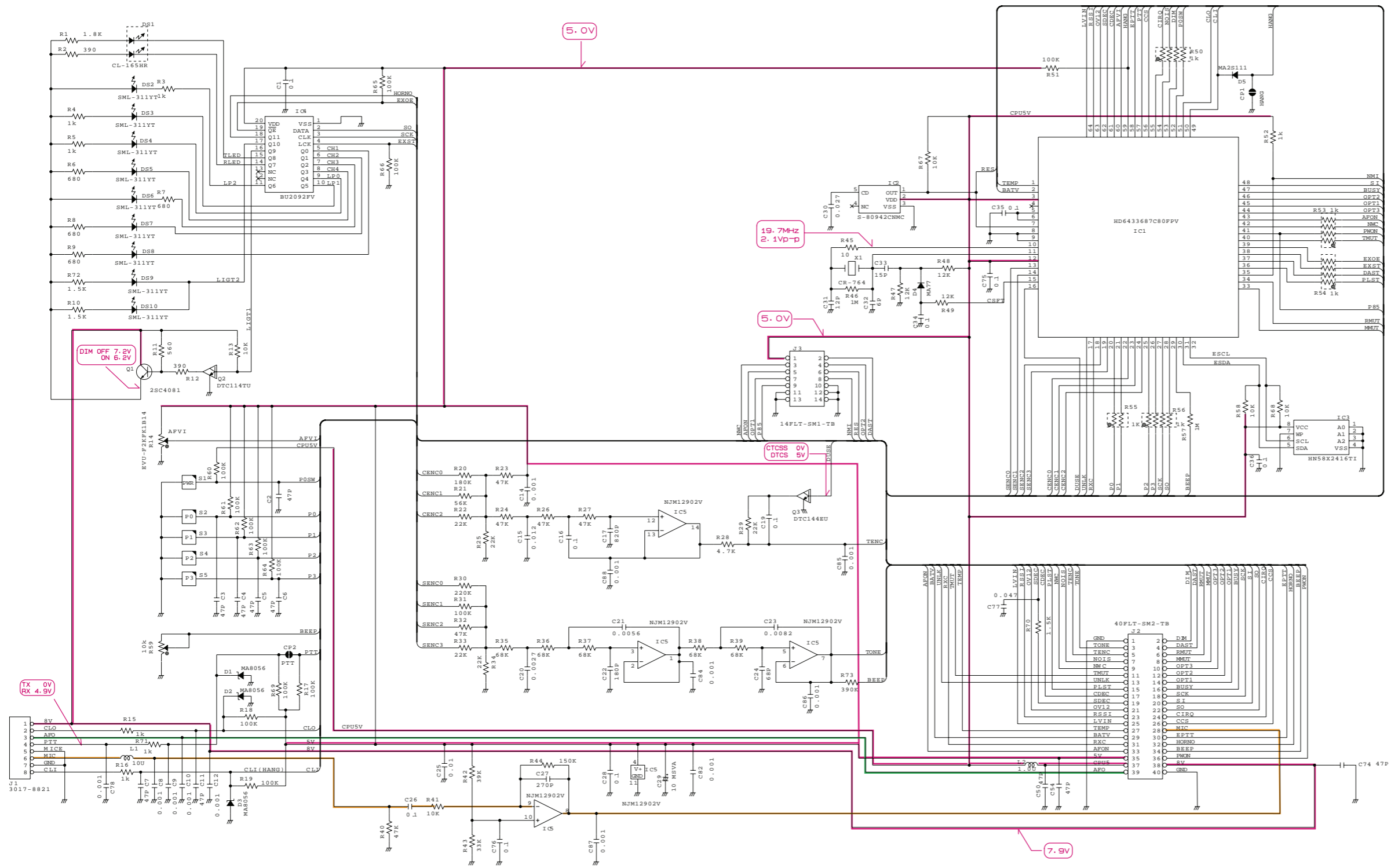



•MAIN UNIT

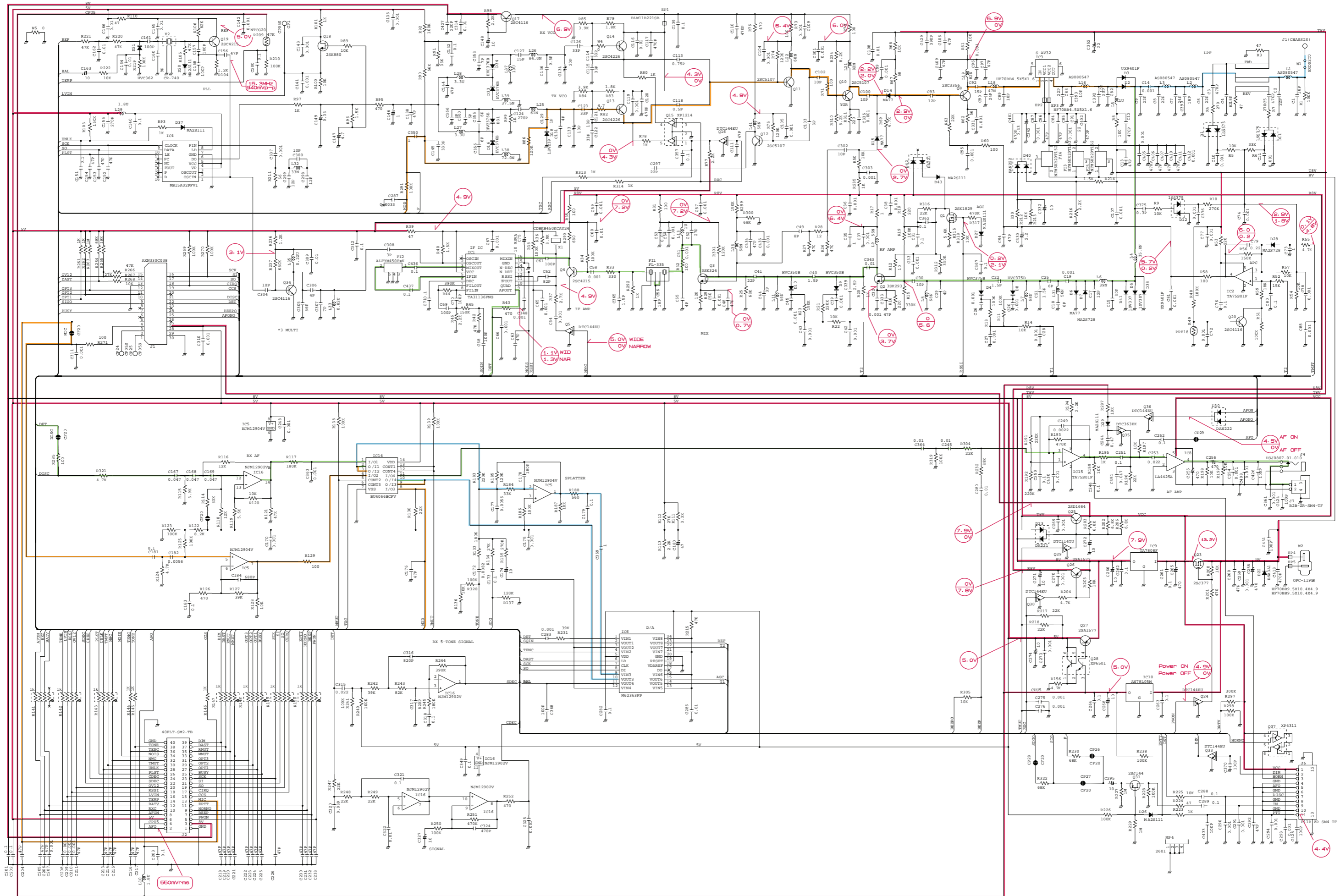

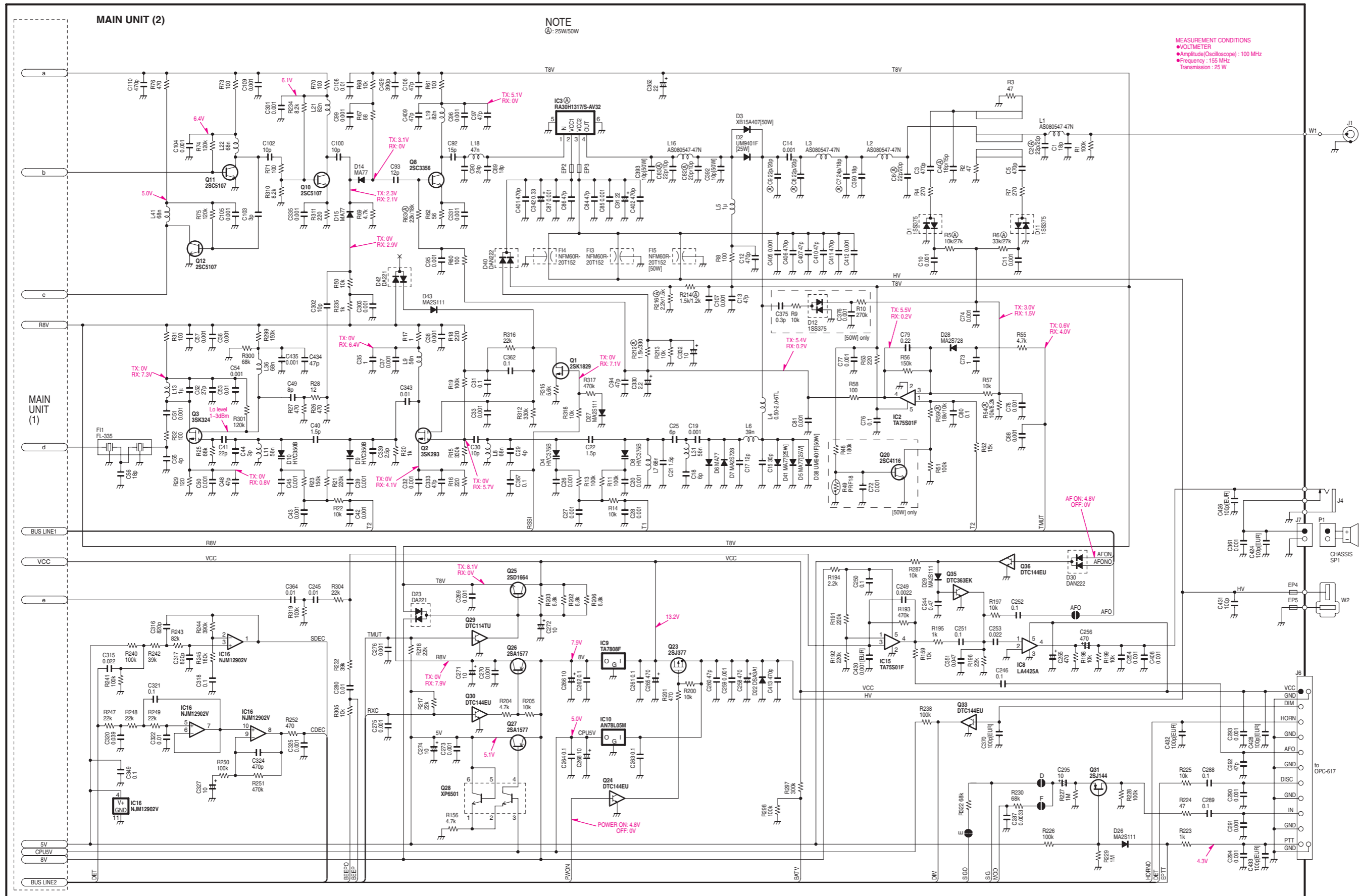

NOTE  
 Ⓐ: 25W/50W

MEASUREMENT CONDITIONS  
 ● VOLTMETER  
 ● Amplitude (Oscilloscope) : 100 MHz  
 ● Frequency : 155 MHz  
 ● Transmission : 25 W

Nov. 2006



# SERVICE MANUAL ADDENDUM

---

## IC-F110S IC-F111S IC-F121S

---

### CONTENTS

PARTS LIST .....	1
MECHANICAL PARTS .....	7
BOARD LAYOUTS .....	8
VOLTAGE DIAGRAM .....	10



[MAIN UNIT]

Table with columns: REF NO., ORDER NO., DESCRIPTION, M., H/V LOCATION. Includes entries for IC1-IC17, Q1-Q38, D1-D51, and F11-F14.

[MAIN UNIT]

Table with columns: REF NO., ORDER NO., DESCRIPTION, M., H/V LOCATION. Includes entries for F15, X1-X2, L1-L43, R1-R45.

M.=Mounted side (T: Mounted on the Top side, B: Mounted on the Bottom side) S.=Surface mount









**[MAIN UNIT]**

REF NO.	ORDER NO.	DESCRIPTION	M.	H/V LOCATION
W11	7030003860	S.RES ERJ3GE JPW V [USA-02], [GEN-02]		
W12	7030003860	S.RES ERJ3GE JPW V [USA-02], [GEN-02] only		
EP1	6910013370	S.BEA BLM18BB221SN1D	B	95.8/29.9
EP2	6910011560	BEA HF70BB4.5X5X1.6		
EP3	6910011560	BEA HF70BB4.5X5X1.6		
EP4	6910010280	BEA HF70BB9.5X10.4X4.9		
EP5	6910010280	BEA HF70BB9.5X10.4X4.9		

M.=Mounted side (T: Mounted on the Top side, B: Mounted on the Bottom side)  
S.=Surface mount

# MECHANICAL PARTS

## [CHASSIS PARTS]

REF NO.	ORDER NO.	DESCRIPTION	QTY.
J1	6510004880	MR-DSE-01	1
W1	8900011800	OPC-1199	1
MP1	8010019063	2601 CHASSIS-3 [Others]	1
	8010019133	2601 LONG CHASSIS-3 [USA-02], [GEN-02]	1
MP2	8110007821	2601 COVER-1	1
MP3	8210019340	2622 FRONT PANEL	1
MP4	8930059010	2622 KEYBOARD	1
MP5	8930059090	2622 LCD PLATE	1
MP6	8210019350	2622 REFLECTOR	1
MP7	8610011180	Knob N-292	1
MP8	8610007420	knob spring NO.6601	1
MP9	8810008661	Screw BT B0 3X8 NI-ZC3 (BT)	8
MP10	8810008661	Screw BT B0 3X8 NI-ZC3 (BT)	2
MP11	8810008661	Screw BT B0 3X8 NI-ZC3 (BT)	2
MP12	8810008761	Screw BT B0 2X8 NI-ZC3 (BT)	3
MP13	8810008661	Screw BT B0 3X8 NI-ZC3 (BT)	1
MP14	8810009991	Screw BT B0 3X8 NI-ZK3 (BT)	4
MP15	8810009991	Screw BT B0 3X8 NI-ZK3 (BT)	2
MP16	8930059100	2622 LCD FILTER	1
MP17	8930059000	2601 SP NET	1

## [FRONT UNIT]

REF NO.	ORDER NO.	DESCRIPTION	QTY.
J1	6450002210	3017-8821	1
DS11	5030002720	L2-0607TAY-1	1
SP1	2510001221	C052SB500-14	1
W1	8900010503	OPC-1046B-1	1
EP2	8930059170	SRCN-2622-SP-N-W	1
MP1	8930059110	2622 SPRING	1
MP2	8930053490	Insulation sheet (GH)	1

## [MAIN UNIT]

REF NO.	ORDER NO.	DESCRIPTION	QTY.
W1	7120000470	ERDS2T0	1
W2	8900011862	OPC-1195B	1
EP2	6910011560	HF70BB4.5X5X1.6 [USA-02], [GEN-02] only	1
EP3	6910011560	HF70BB4.5X5X1.6 [USA-02], [GEN-02] only	1
EP4	6910010280	HF70BB9.5X10.4X4.9	1
EP5	6910010280	HF70BB9.5X10.4X4.9	1
MP1	8510002280	VCO shield plate (A)	1
MP5	8510014950	2601 VCO COVER	1
MP6	8510014910	2601 FILTER CASE	1
MP7	8510015110	2602 M-PLATE	1
MP9	8930058990	SHIELD SPONGE (V)	1
MP10	8930058840	SHIELD SPONGE (T)	1
		[GEN-02], [USA-02], [GEN-02] only	1
MP11	8930058840	SHIELD SPONGE (T)	1
MP12	8930061830	THERMALLY SHEET (AN) [USA-02], [GEN-02] only	1

## [ACCESSORIES]

REF NO.	ORDER NO.	DESCRIPTION	QTY.
MC1	Optional product	HM-152	1
W1	Optional product	OPC-1194A [Others]	1
	Optional product	OPC-1132 [USA-02], [GEN-02]	1
W2	8900000730	OPC-049	1
MP1	8010019151	2601 MOBIL BRACKET-1	1
MP2	8930059160	2601 FELT	2
MP3	8820000530	Flange bolt M4X8 NI	4
MP4	8810000471	Screw PH (+-) M5X12 ZC3	4
MP5	8810005841	Screw BT A0 5X20 ZC3	4
MP6	8850000150	Flat washerM5 BS NI	4
MP7	8850000391	SPRING WASHER M5 ZC3	4
MP8	8830000121	Nut M5 ZC3	4
MP9	8950005110	2289 MIC HANGER	1
MP10	8310054770	1705 LCD SEAL (F)	1
MP11	8810004700	Screw BT A0 3X16 SUS	2

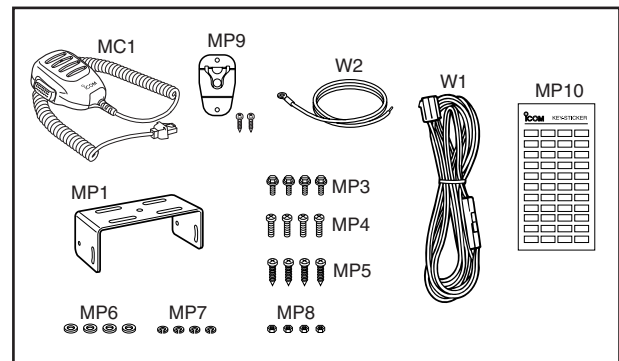

**Screw abbreviations**

A, B0, BT: Self-tapping PH: Pan head ZK: Black NI-ZU: Nickel-Zinc SUS: Stainless



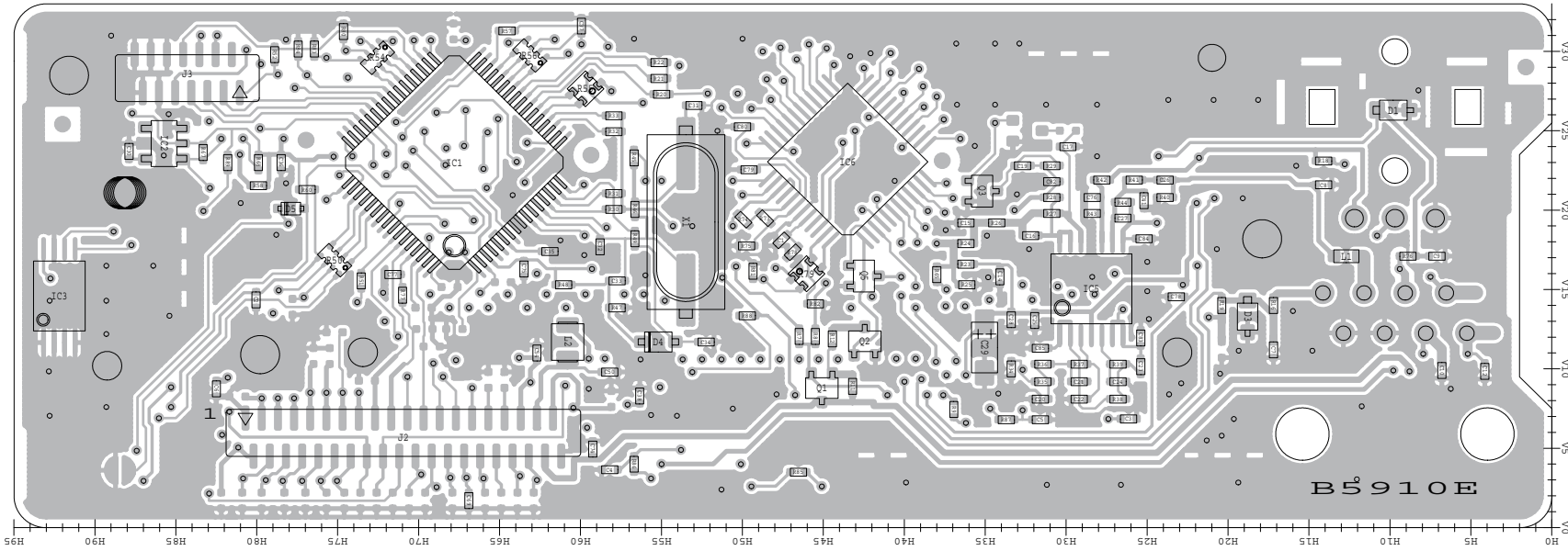

• FRONT UNIT  
(BOTTOM VIEW)

The combination of this side and the bottom side shows the board layout in the same configuration as the actual P.C.Board.

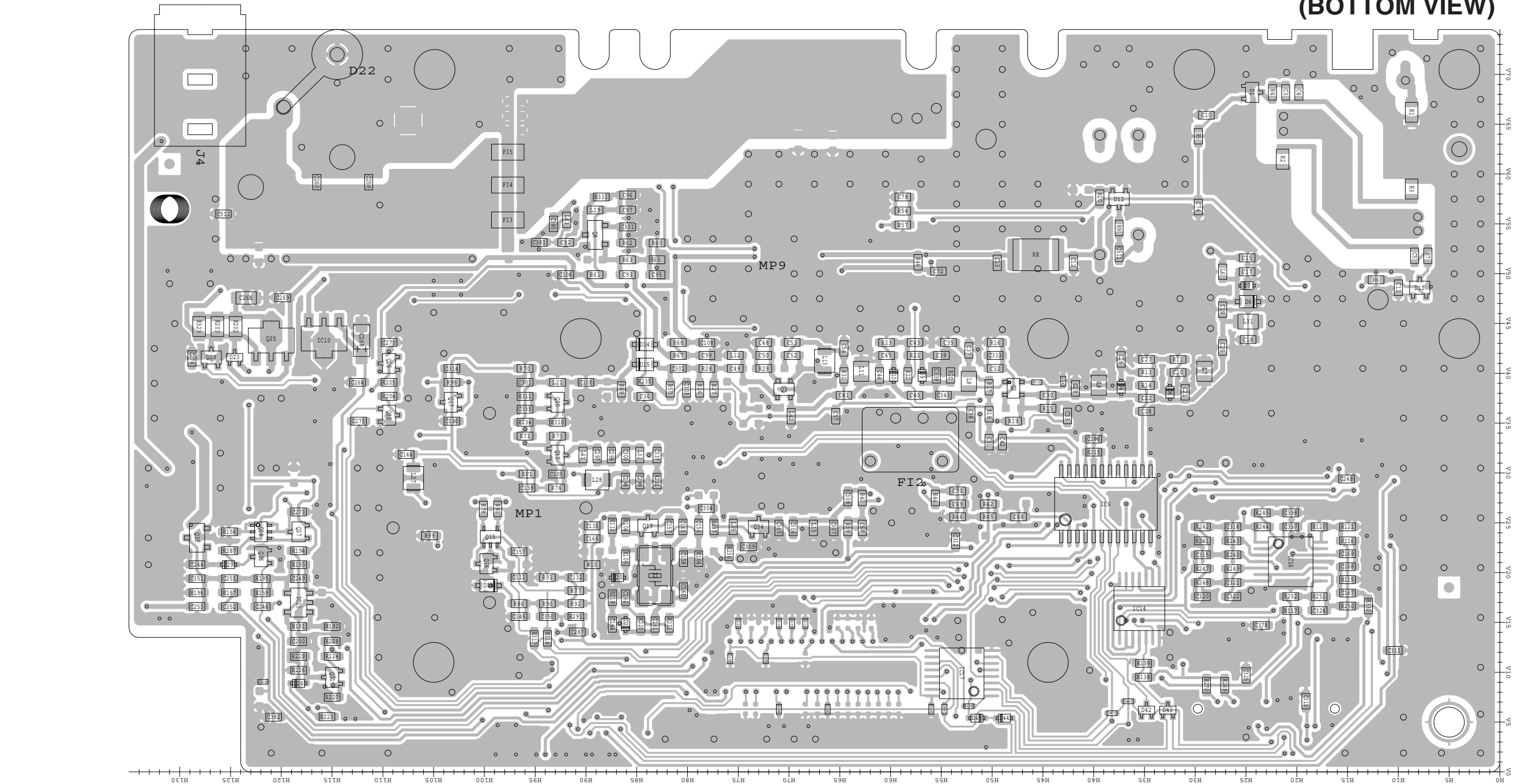

• MAIN UNIT  
(BOTTOM VIEW)

# VOLTAGE DIAGRAM

## •FRONT UNIT

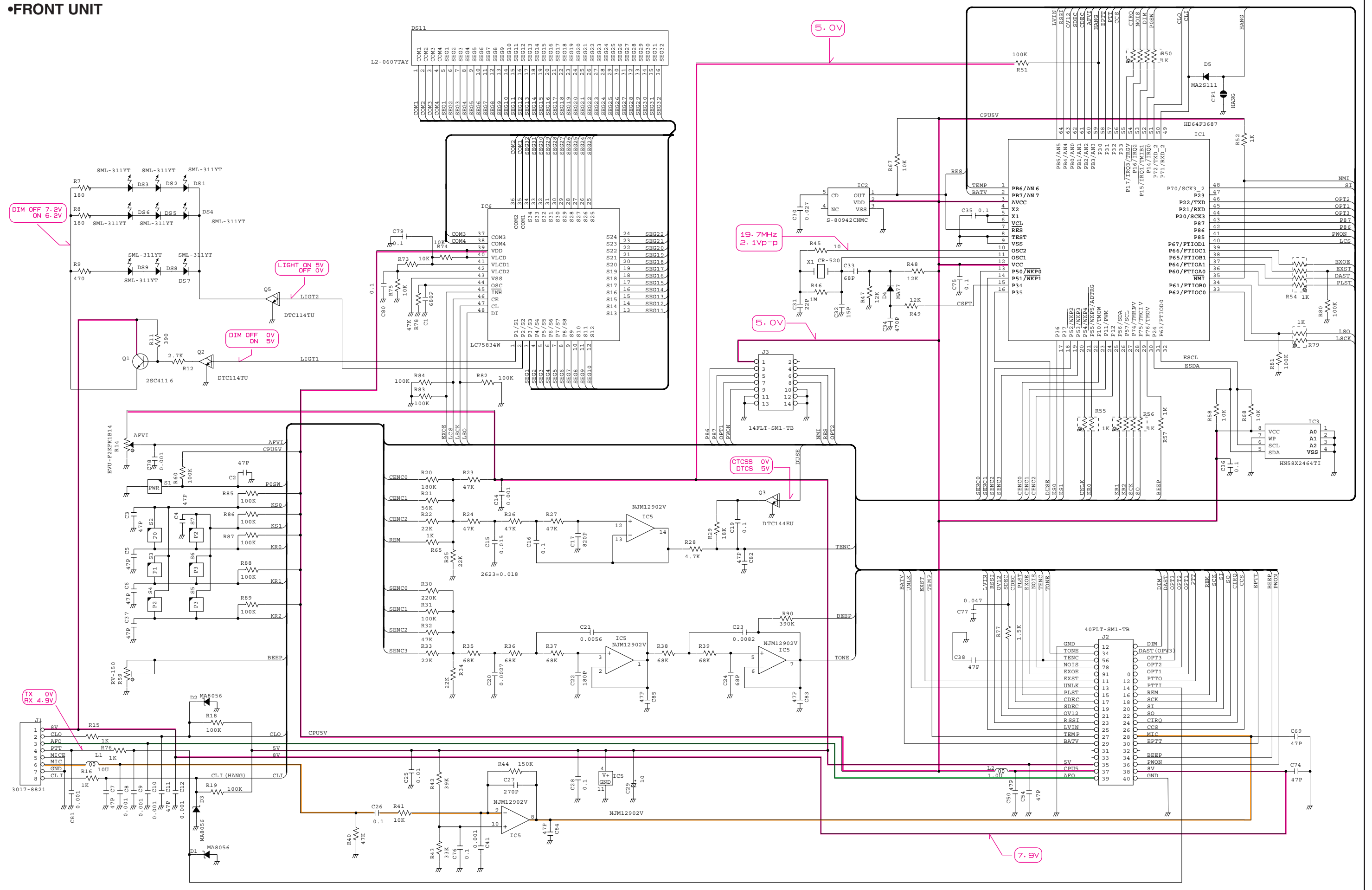

•MAIN UNIT

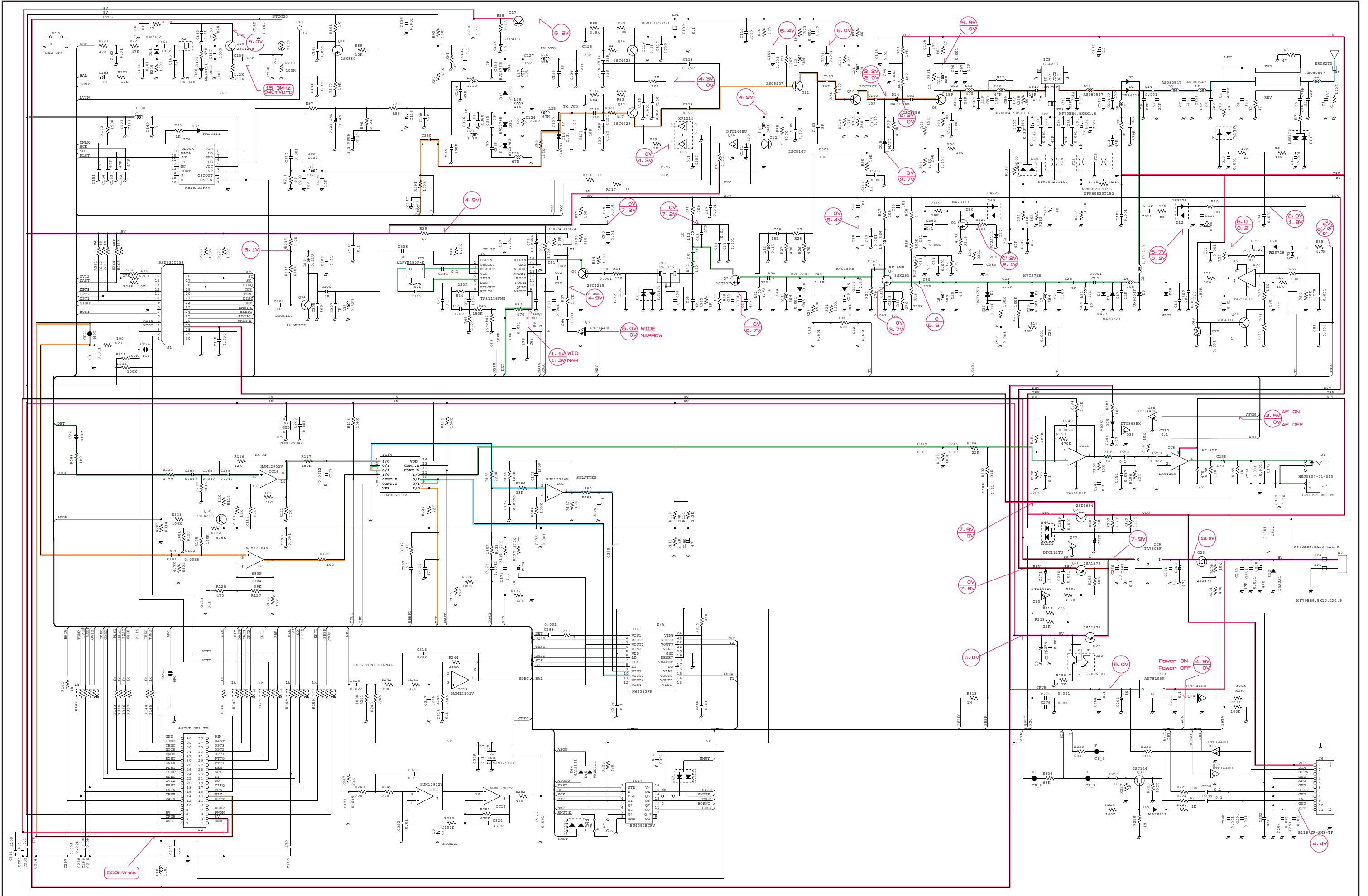



# SERVICE MANUAL

VHF TRANSCEIVER

**IC-F110S**  
**IC-F111S**  
**IC-F121S**

---

---

---

---

---

---

## INTRODUCTION

---

This service manual describes the latest service information for the **IC-F110S, IC-F111S and IC-F121S** VHF MOBILE TRANSCEIVER at the time of publication.

MODEL	VERSION	SYMBOL
IC-F110S	Europe	EUR
	General	GEN
IC-F111S	General	GEN
IC-F121S	U.S.A.	USA

To upgrade quality, any electrical or mechanical parts and internal circuits are subject to change without notice or obligation.

---

## DANGER

---

**NEVER** connect the transceiver to an AC outlet or to a DC power supply that uses more than 16 V. This will ruin the transceiver.

**DO NOT** expose the transceiver to rain, snow or any liquids.

**DO NOT** reverse the polarities of the power supply when connecting the transceiver.

**DO NOT** apply an RF signal of more than 20 dBm (100 mW) to the antenna connector. This could damage the transceiver's front end.



---

## ORDERING PARTS

---

Be sure to include the following four points when ordering replacement parts:

1. 10-digit order numbers
2. Component part number and name
3. Equipment model name and unit name
4. Quantity required

### <SAMPLE ORDER>

1110003490 S.IC TA31136FN IC-F110S MAIN UNIT 5 pieces  
8810009990 Screw PH BT M3×8 ZK IC-F110S Bottom cover 10 pieces

Addresses are provided on the inside back cover for your convenience.

---

## REPAIR NOTES

---

1. Make sure a problem is internal before disassembling the transceiver.
2. **DO NOT** open the transceiver until the transceiver is disconnected from its power source.
3. **DO NOT** force any of the variable components. Turn them slowly and smoothly.
4. **DO NOT** short any circuits or electronic parts. An insulated tuning tool **MUST** be used for all adjustments.
5. **DO NOT** keep power ON for a long time when the transceiver is defective.
6. **DO NOT** transmit power into a signal generator or a sweep generator.
7. **ALWAYS** connect a 40 dB to 50 dB attenuator between the transceiver and a deviation meter or spectrum analyzer when using such test equipment.
8. **READ** the instructions of test equipment thoroughly before connecting equipment to the transceiver.



---

## EXPLICIT DEFINITIONS

---

### FREQUENCY COVERAGE

136 – 174 MHz
---------------

### CHANNEL SPACING

	12.5 kHz/ 25.0 kHz
Narrow/Wide-type	15.0 kHz/ 30.0 kHz
Narrow/Middle-type	15.0 kHz/ 20.0 kHz

---

## TABLE OF CONTENTS

---

<b>SECTION 1</b>	<b>SPECIFICATIONS</b>	
<b>SECTION 2</b>	<b>INSIDE VIEW</b>	
<b>SECTION 3</b>	<b>DISASSEMBLY INSTRUCTIONS</b>	
<b>SECTION 4</b>	<b>CIRCUIT DESCRIPTION</b>	
4 - 1	RECEIVER CIRCUITS .....	4 - 1
4 - 2	TRANSMITTER CIRCUITS .....	4 - 2
4 - 3	PLL CIRCUITS .....	4 - 3
4 - 4	POWER SUPPLY CIRCUITS .....	4 - 4
4 - 5	PORT ALLOCATIONS .....	4 - 4
<b>SECTION 5</b>	<b>ADJUSTMENT PROCEDURES</b>	
5 - 1	PREPARATION .....	5 - 1
5 - 2	PLL ADJUSTMENT .....	5 - 4
5 - 3	SOFTWARE ADJUSTMENT .....	5 - 5
5 - 4	TRIMMER ADJUSTMENT .....	5 - 7
<b>SECTION 6</b>	<b>PARTS LIST</b>	
<b>SECTION 7</b>	<b>MECHANICAL PARTS</b>	
<b>SECTION 8</b>	<b>SEMI-CONDUCTOR INFORMATION</b>	
<b>SECTION 9</b>	<b>BOARD LAYOUTS</b>	
9 - 1	FRONT UNIT .....	9 - 1
9 - 2	MAIN UNIT .....	9 - 3
<b>SECTION 10</b>	<b>BLOCK DIAGRAM</b>	
<b>SECTION 11</b>	<b>VOLTAGE DIAGRAMS</b>	
11 - 1	FRONT UNIT .....	11 - 1
11 - 2	MAIN UNIT .....	11 - 2

# SECTION 1 SPECIFICATIONS

		[GEN], [USA]	[EUR]
GENERAL	Measurement method	EIA-152-C/204D or TIA-603	EN 300 086
	Frequency coverage	136.000–174.000 MHz	
	Type of emission	N/W: (12.5 kHz; Narrow/25 kHz; Wide): 8K50F3E/16K0F3E (12.5 kHz; Narrow/25 kHz; Wide): 11K0F3E/16K0F3E (15 kHz; Narrow/30 kHz; Wide): 11K0F3E/16K0F3E N/M: (12.5 kHz; Narrow/20 kHz; Middle): 8K50F3E/14K0F3E	[EUR] [GEN] [USA] [EUR]
	Number of conventional channels	Free: 8 channels, Bank: 4 channels × 2 banks	
	Antenna impedance	50 Ω nominal (SO-293)	
	Power supply voltage (negative ground)	13.2 V DC nominal 13.6 V DC nominal	[25 W] [50 W]
	Current drain (approx.)	TX: 7.0 A(at 25 W), 14.0 A(at 50 W) RX: 1200 mA(max. audio) 300 mA(stand-by)	
	Usable temperature range	–30°C to +60°C (–22°F to +140°F)	–25°C to +55°C (–13°F to +131°F)
	Dimensions (proj. not included)	150(W) × 40(H) × 117.5(D) mm; 5 <sup>29</sup> / <sub>32</sub> (W) × 1 <sup>9</sup> / <sub>16</sub> (H) × 4 <sup>5</sup> / <sub>8</sub> (D) inch 150(W) × 40(H) × 167.5(D) mm; 5 <sup>29</sup> / <sub>32</sub> (W) × 1 <sup>9</sup> / <sub>16</sub> (H) × 4 <sup>19</sup> / <sub>32</sub> (D) inch	[25 W] [50 W]
	Weight	0.8 kg; 1 lb 12 oz [25 W], 1.1 kg; 2 lb 7 oz [50 W]	
TRANSMITTER	RF output power	High/Low2/Low1: 25 W/10 W/2.5 W 50 W/25 W/5 W	[25 W] [50 W]
	Modulation system	Variable reactance frequency modulation	
	Maximum permissible deviation	±2.5 kHz [Narrow], ±4.0 kHz [Middle], ±5.0 kHz [Wide]	
	Frequency error	±5.0 ppm	±1.5 kHz
	Spurious emissions	70 dBc typical	0.25 μW ≤ 1GHz, 1.0 μW > 1 GHz
	Adjacent channel power	60 dB [Narrow], 70 dB [Middle], [Wide]	
	Audio frequency response	+2 dB to –8 dB of 6 dB/octave range from 300 Hz to 2550 Hz [Narrow]/3000 Hz [Middle], [Wide]	
	Audio harmonic distortion	3% typical at 1 kHz, 40% deviation	
	FM hum and noise (typical) (without CCICT filter)	40 dB [Narrow], 46 dB [Wide]	—
	Residual modulation (typical) (with CCICT filter)	—	50 dB [Narrow], 53 dB [Middle] 55 dB [Wide]
	Limiting charact of modulator	70–100% of max. deviation	
	Microphone connector	8-pin modular (600 Ω)	
RECEIVER	Receive system	Double-conversion superheterodyne system	
	Intermediate frequencies	1st: 46.35 MHz, 2nd: 450 kHz	
	Sensitivity (typical)	0.25 μV at 12 dB SINAD	–4 dBμV (emf) at 20 dB SINAD
	Squelch sencitivity (at threshold) (typical)	0.25 μV	–4 dBμV (emf)
	Adjcent channel selectivity (typical)	65 dB [Narrow], 75 dB [Middle]/[Wide]	
	Spurious response	75 dB	
	Intermodulation (typical)	74 dB	67 dB
	Hum and noise (typical)	(without CCITT filter) (with CCITT filter)	40 dB [Narrow], 45 dB [Wide] — 50 dB [Narrow], 53 dB [Middle], 55 dB [Wide]
	Audio output power	4 W typical at 10% distortion with a 4 Ω load	
	External SP connector	2-conductor 3.5 (d) mm (1/8")/4 Ω	

All stated specifications are subject to change without notice or obligation.

## SECTION 2 INSIDE VIEW

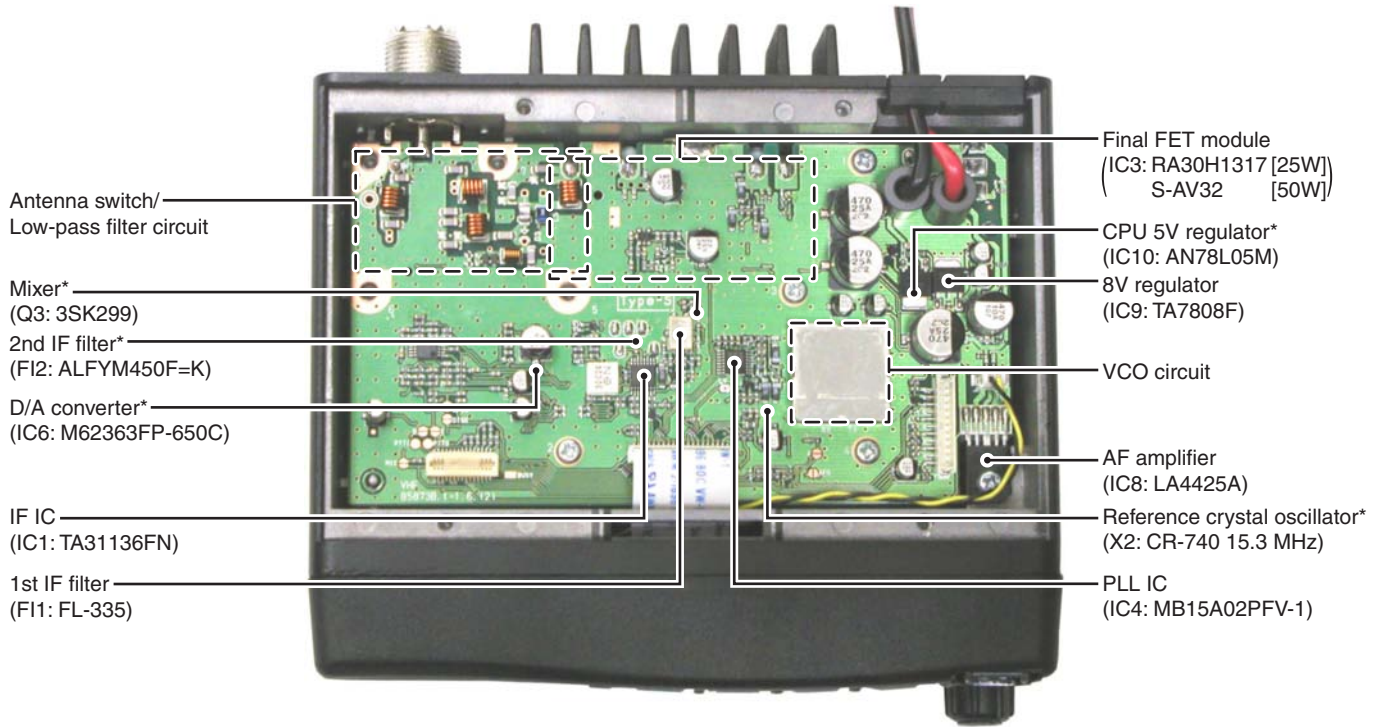

Antenna switch/  
Low-pass filter circuit

Mixer\*  
(Q3: 3SK299)

2nd IF filter\*  
(FI2: ALFYM450F=K)

D/A converter\*  
(IC6: M62363FP-650C)

IF IC  
(IC1: TA31136FN)

1st IF filter  
(FI1: FL-335)

Final FET module  
(IC3: RA30H1317 [25W]  
S-AV32 [50W])

CPU 5V regulator\*  
(IC10: AN78L05M)

8V regulator  
(IC9: TA7808F)

VCO circuit

AF amplifier  
(IC8: LA4425A)

Reference crystal oscillator\*  
(X2: CR-740 15.3 MHz)

PLL IC  
(IC4: MB15A02PFV-1)

\* Located under side of the point.

## SECTION 3 DISASSEMBLY INSTRUCTIONS

### • Opening case and remove the front panel

- ① Unscrew 4 screws (A), and remove the bottom cover.
- ② Disconnect the flat cable (B) from J2.
- ③ Disconnect the cable (C) from J7.
- ④ Unscrew 2 screws (D), and remove the front unit in the direction of the arrow.

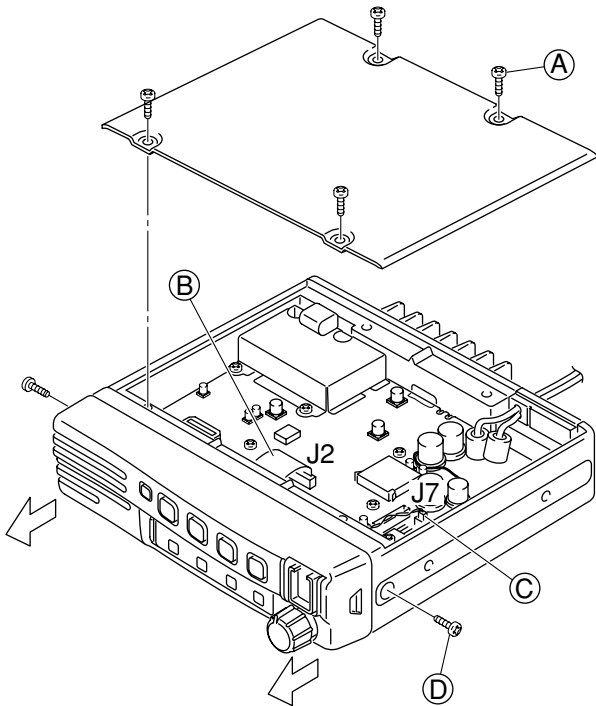

### • Removing the main unit

- ① Unscrew 8 screws (E).
- ② Remove the filter case (F).
- ③ Unscrew the screw (G).
- ④ Unsolder 3 points (H) from the antenna connector.
- ⑤ Unsolder 4 points (I) from IC3.

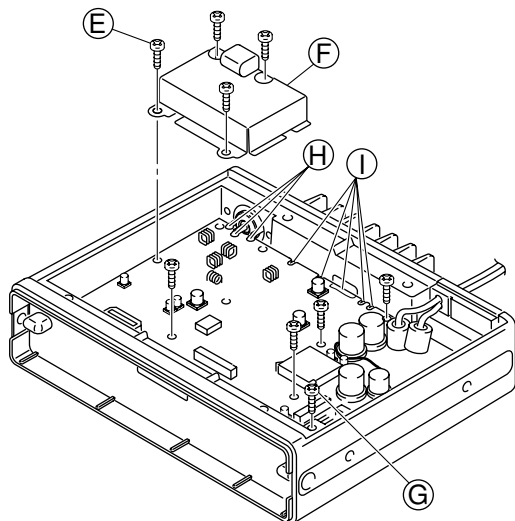

- ⑥ Lift up the front portion of the main unit and remove it.

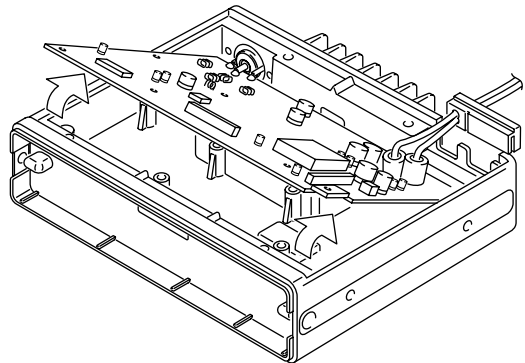

### • Installation location

- |         |  |
|---------|--|
| UT-108  | DTMF decoder unit                            |
| UT-109  | Voice scrambler unit                         |
| UT-110  |  |
| OPC-617 | ACC cable (for external terminal connection) |

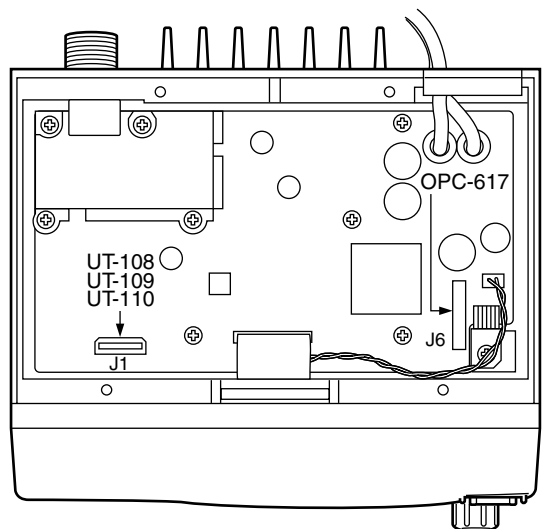

## SECTION 4 CIRCUIT DESCRIPTION

### 4-1 RECEIVER CIRCUITS

#### 4-1-1 ANTENNA SWITCHING CIRCUIT (MAIN UNIT)

The antenna switching circuit functions as a low-pass filter while receiving and as resonator circuit while transmitting. This circuit does not allow transmit signals to enter the receiver circuits.

Received signals enter the antenna connector and pass through the low-pass filter (L1–L3, C1, C2, C6–C8). The filtered signals are then applied to the RF circuit passed through the  $\lambda/4$  type antenna switching circuit (D5, D6, D41, L6).

#### 4-1-2 RF CIRCUIT (MAIN UNIT)

The RF circuit amplifies signals within the range of frequency coverage and filters out-of-band signals.

The signals from the antenna switching circuit pass through the two-stage tunable bandpass filters (D8, D4). The filtered signals are amplified at the RF amplifier (Q2) and then enter other two-stage bandpass filters (D9, D10) to suppress unwanted signals. The filtered signals are applied to the 1st mixer circuit (Q3).

The tunable bandpass filters (D4, D8–D10) employ varactor diodes to tune the center frequency of the RF passband for wide bandwidth receiving and good image rejection. These diodes are controlled by the CPU (FRONT unit; IC1) via the D/A converter (IC6).

The gate control circuit reduces RF amplifier gain and attenuates RF signal to keep the audio output at a constant level.

The receiver gain is determined by the voltage on the "RSSI" line from the FM IF IC (IC1, pin 12). The gate control circuit (Q1) supplies control voltage to the RF amplifier (Q2) and sets the receiver gain.

When receiving strong signals, the "RSSI" voltage increases and the gate control voltage decreases. As the gate control voltage is used for the bias voltage of the RF amplifier (Q2), then the RF amplifier gain is decreased.

#### • 2nd IF and demodulator circuits

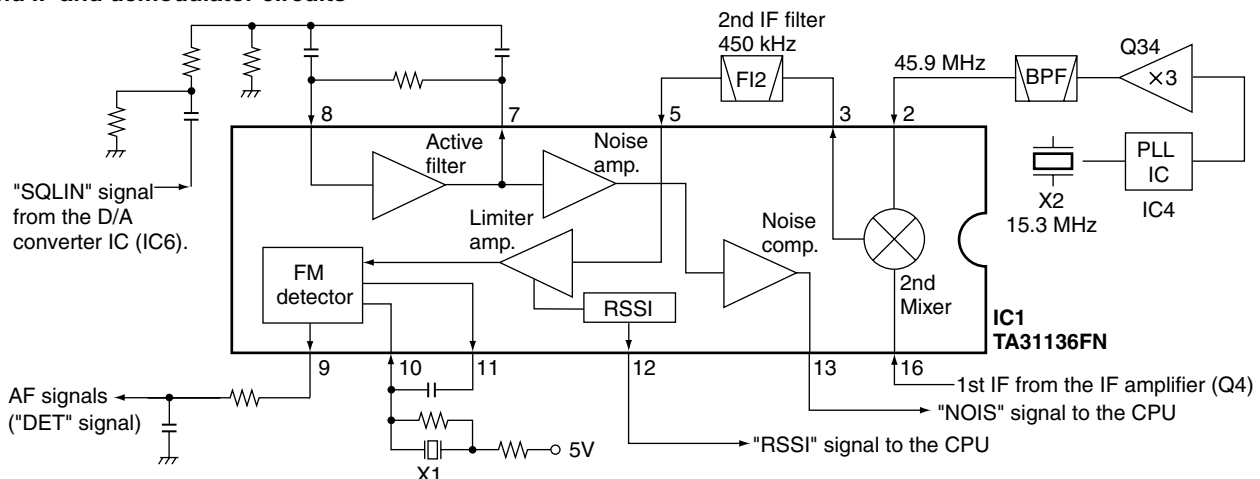

#### 4-1-3 1ST MIXER AND 1ST IF CIRCUITS (MAIN UNIT)

The 1st mixer circuit converts the received signals to a fixed frequency of the 1st IF signal with the PLL output frequency. By changing the PLL frequency, only the desired frequency will pass through a MCF (Monolithic Crystal Filter; F11) at the next stage of the 1st mixer.

The RF signals from the bandpass filter are applied to the 1st mixer circuit (Q3). The applied signals are mixed with the 1st LO signal coming from the RX VCO circuit (Q14) to produce a 46.35 MHz 1st IF signal. The 1st IF signal passes through a MCF (Monolithic Crystal Filter; F11) to suppress out-of-band signals. The filtered signal is amplified at the 1st IF amplifier (Q4) and applied to the 2nd IF circuit.

#### 4-1-4 2ND IF AND DEMODULATOR CIRCUITS (MAIN UNIT)

The 2nd mixer circuit converts the 1st IF signal to a 2nd IF signal. A double-conversion superheterodyne system improves the image rejection ratio and obtains stable receiver gain.

The 1st IF signal from the 1st IF amplifier (Q4) is applied to the 2nd mixer section of the FM IF IC (IC1, pin 16) and is then mixed with the 2nd LO signal for conversion to a 450 kHz 2nd IF signal.

IC1 contains the 2nd mixer, limiter amplifier, quadrature detector, active filter and noise amplifier circuits, etc. A tripled frequency from the PLL reference oscillator is used for the 2nd LO signal (45.9 MHz).

The 2nd IF signal from the 2nd mixer (IC1, pin 3) passes through a ceramic filter (F12) to remove unwanted heterodyned frequencies. It is then amplified at the limiter amplifier section (IC1, pin 5) and applied to the quadrature detector section (IC1, pins 10, 11 and X1) to demodulate the 2nd IF signal into AF signals.

The AF signals are output from pin 9 (IC1) and are then applied to the AF amplifier circuit.

#### **4-1-5 AF AMPLIFIER CIRCUIT (MAIN UNIT)**

The AF amplifier circuit amplifies the demodulated AF signals to drive a speaker.

The AF signals from the FM IF IC (IC1, pin 9) are applied to the active filter circuit (IC16). The active filter circuit (high-pass filter) removes CTCSS or DTCS signals.

The filtered AF signals are output from pin 14 (IC16) and are applied to the de-emphasis circuit (R117, C363) with frequency characteristics of  $-6$  dB/octave, and then passed through the analog switch (IC14, pins 1, 2) and low-pass filter (IC5 pins 1, 2). The filtered signal is applied to the electronic volume controller (IC6, pin 9).

The output AF signals from the electronic volume controller (IC6, pin 10) are passed through the analog switch (IC14 pins 10, 11) and are applied to the AF pre-amplifier (IC15) and AF power amplifier (IC8) to drive the speaker.

#### **4-1-6 RECEIVER MUTE CIRCUITS (MAIN AND FRONT UNITS)**

##### **• NOISE SQUELCH**

The noise squelch circuit cuts out AF signals when no RF signals are received. By detecting noise components in the AF signals, the squelch circuit switches the AF mute switch.

Some noise components in the AF signals from the FM IF IC (IC1, pin 9) are passed through the level controller (IC6, pins 1, 2). The level controlled signals are applied to the active filter section in the FM IF IC (IC1, pin 8) as "SQLIN" signal. Noise components about 10 kHz are amplified and output from pin 7.

The filtered signals are converted to the pulse-type signals at the noise detector section and output from pin 13 (NOIS).

The "NOIS" signal from the FM IF IC is applied to the CPU (FRONT unit; IC1, pin 53). The CPU then analyzes the noise condition and controls the AF mute signal via "AFON" line (FRONT unit; IC1, pin 43) to the AF regulator (Q35, Q36, D29, D30).

##### **• CTCSS AND DTCS**

The tone squelch circuit detects AF signals and opens the squelch only when receiving a signal containing a matching subaudible tone (CTCSS or DTCS). When tone squelch is in use, and a signal with a mismatched or no subaudible tone is received, the tone squelch circuit mutes the AF signals even when noise squelch is open.

A portion of the AF signals from the FM IF IC (IC1, pin 9) passes through the low-pass filter (IC16) to remove AF (voice) signals and is applied to the CTCSS or DTCS decoder inside the CPU (FRONT unit; IC1, pin 50) via the "CDEC" line to control the AF mute switch.

#### **4-2 TRANSMITTER CIRCUITS**

##### **4-2-1 MICROPHONE AMPLIFIER CIRCUIT (MAIN AND FRONT UNITS)**

The microphone amplifier circuit amplifies audio signals within  $+6$  dB/octave pre-emphasis characteristics from the microphone to a level needed for the modulation circuit.

The AF signals (MIC) from the MIC jack (FRONT unit; J1) are amplified at the AF amplifier (FRONT unit; IC5) and applied to the MAIN unit via J2 (pin 13). The AF signal are applied to the limiter amplifier (IC5, pin 5).

The entered signals are pre-emphasized with  $+6$ dB/octave at a limiter amplifier, then passed through the analog switch (IC14, pins 4, 3) and splatter filter (IC5, pins 2, 1). The output signals from the splatter filter are applied to the level controller (IC6, pins 9, 10).

The deviation level controlled signals are then applied to the modulation circuit (D18) as the "MOD" signal after being passed through the analog switch (IC14, pins 9, 8).

##### **4-2-2 MODULATION CIRCUIT (MAIN UNIT)**

The modulation circuit modulates the VCO oscillating signal (RF signal) using the microphone audio signals.

The AF signals from the analog switch (IC14, pin 8) change the reactance of varactor diode (D18) to modulate the oscillated signal at the TX VCO circuit (Q13, D16, D31). The modulated VCO signal is amplified at the buffer amplifiers (Q11, Q10) and is then applied to the drive amplifier circuit via the T/R switch (D14).

The CTCSS/DTCS signals from the CPU (FRONT unit; IC1, pins 13, 14, 19, 20) are passed through the low-pass filter (FRONT unit; IC5), and mixer and splatter filter (IC5), and are then applied to the VCO circuit.

##### **4-2-3 DRIVE AMPLIFIER CIRCUIT (MAIN UNIT)**

The drive amplifier circuit amplifies the VCO oscillating signal to the level needed at the power amplifier.

The RF signal from the buffer amplifier (Q10) passes through the T/R switch (D14) and is amplified at the drive amplifier circuit (Q8). The amplified signal is applied to the power amplifier circuit.

#### 4-2-4 POWER AMPLIFIER CIRCUIT (MAIN UNIT)

The power amplifier circuit amplifies the driver signal to an output power level.

The RF signal from the drive amplifier (Q8) is passed through the low-pass filter circuit (L18, C90, C89) and applied to the power module (IC3) to obtain 25 W or 50 W of RF power.

The amplified signal is passed through the antenna switching circuit (D2, D3), low-pass filter and APC detector, and is then applied to the antenna connector.

Control voltage for the power amplifier (IC3, pin 2) comes from the APC amplifier (IC2) to stabilize the output power. The transmit mute switch (D28) controls the APC amplifier when transmit mute is necessary.

#### 4-2-5 APC CIRCUIT (MAIN UNIT)

The APC circuit protects the power amplifier from a mismatched output load and stabilizes the output power.

The APC detector circuit detects forward signals and reflection signals at D1 and D11 respectively. The combined voltage is at minimum level when the antenna impedance is matched at 50  $\Omega$ , and is increased when it is mismatched.

The detected voltage is applied to the APC amplifier (IC2, pin 3), and the power setting "T2" signal from the D/A converter (IC6, pin 22), controlled by the CPU (FRONT unit; IC1), is applied to the other input for reference. When antenna impedance is mismatched, the detected voltage exceeds the power setting voltage. Then the output voltage of the APC amplifier (IC2, pin 4) controls the input current of the drive amplifier (Q8) and power module (IC3) to reduce the output power.

### 4-3 PLL CIRCUITS

#### 4-3-1 PLL CIRCUIT (MAIN UNIT)

A PLL circuit provides stable oscillation of the transmit frequency and receive 1st LO frequency. The PLL output compares the phase of the divided VCO frequency to the reference frequency. The PLL output frequency is controlled by the divided ratio (N-data) of a programmable divider.

The PLL circuit contains the TX/RX VCO circuit (Q13, Q14). The oscillated signal is amplified at the buffer amplifiers (Q11, Q12) and then applied to the PLL IC (IC4, pin 8) via the low-pass filter (L32, C298–C300).

The PLL IC contains a prescaler, programmable counter, programmable divider and phase detector, etc. The entered signal is divided at the prescaler and programmable counter section by the N-data ratio from the CPU. The reference signal is generated at the reference oscillator (X2) and is also applied to the PLL IC. The PLL IC detects the out-of-step phase using the reference frequency, and outputs it from pin 5. The output signal is passed through the loop filter (R97/C149, R96/C147), and is then applied to the VCO circuit as the lock voltage.

If the oscillated signal drifts, its phase changes from that of the reference frequency, causing a lock voltage change to compensate for the drift in the oscillated frequency.

#### 4-3-2 VCO CIRCUIT (MAIN UNIT)

The VCO circuit contains a separate RX VCO (Q14, D33, D34) and TX VCO (Q13, D16, D18, D31). The oscillated signal is amplified at the buffer amplifiers (Q11, Q10) and is then applied to the T/R switch circuit (D14, D15). Then the receive 1st LO (RX) signal is applied to the 1st mixer (Q3) and the transmit (TX) signal to the drive amplifier circuit (Q8).

A portion of the signal from the buffer amplifier (Q11) is fed back to the PLL IC (IC4, pin 8) via the buffer amplifier (Q12) and low-pass filter (L32, C298-C300) as the comparison signal.

#### • PLL circuit

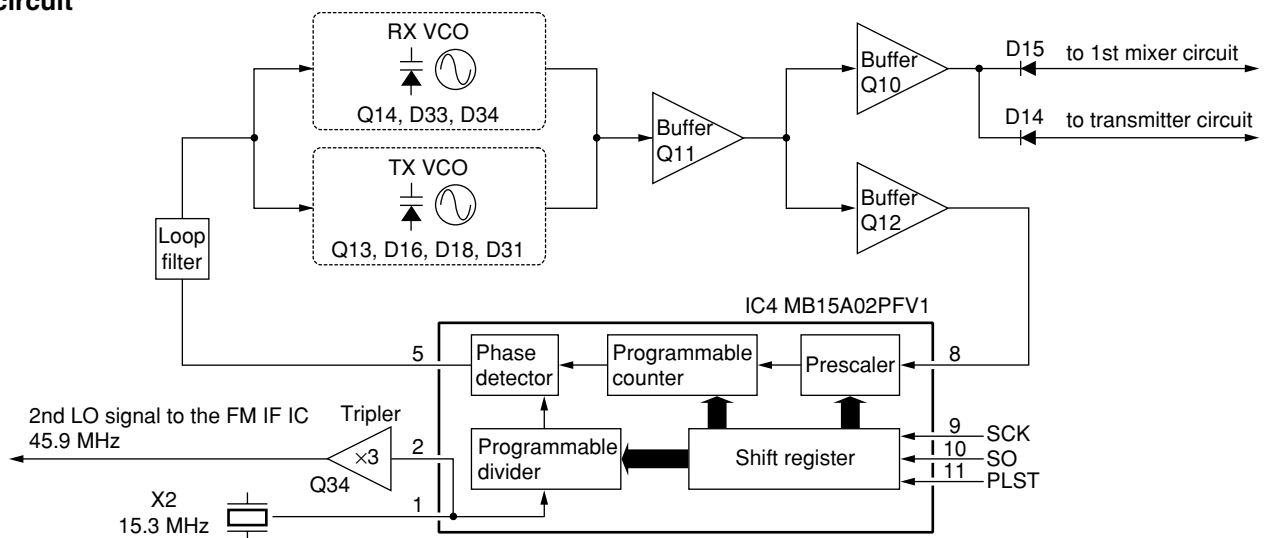

## 4-4 POWER SUPPLY CIRCUITS

### 4-4-1 VOLTAGE LINES (MAIN UNIT)

Line	Description
HV	The voltage from a DC power supply.
VCC	The same voltage as the HV line which is controlled by the power switching circuit (Q23, Q24). When the [POWER] switch is pushed, the CPU outputs the "PWON" control signal to the power switching circuit to turn the circuit ON.
CPU5V	Common 5 V for the CPU converted from the HV line by the CPU5V regulator circuit (IC10). The circuit outputs the voltage regardless of the power ON/OFF condition.
8V	Common 8 V converted from the VCC line by the 8V regulator circuit (IC9).
5V	Common 5 V converted from the VCC line by the 5V regulator circuit (Q27, Q28).
R8V	Receive 8 V controlled by the R8 regulator circuit (Q26, Q30) using the "RXC" signal from the CPU (FRONT unit; IC1, pin 18).
T8V	Transmit 8 V controlled by the T8 regulator circuit (Q25, Q29, D23) using the "TMUT" signal from the CPU (FRONT unit; IC1, pin 40).

## 4-5 PORT ALLOCATIONS

### 4-5-1 LED DRIVER (FRONT UNIT; IC4)

Pin number	Port name	Description
5–11	CH1–CH4 LP0–LP2	Output LEDs control signals. Low : While LEDs are ON.
14	RLED	Outputs BUSY LED control signal.
15	TLED	Outputs TX LED control signal.
16	LIGT1	Outputs LED bright control signal.
17	LIGT2	Outputs backlight control signal.
18	HORN	Outputs external device control signal. High : When matched 5/2 tone signals are received.

### 4-5-2 OUTPUT EXPANDER (MAIN UNIT; IC6)

Pin number	Port name	Description
2	VOUT1	Outputs squelch control signal.
3	VOUT2	Outputs deviation (Tone) control signal.
10	VOUT3	Outputs deviation control signal.
11	VOUT4	Outputs DTCS control signal.
14	VOUT5	Outputs RX BPF control signal.
15	VOUT6	Outputs AGC control signal.
22	VOUT7	Outputs TX RF power control signal.
23	VOUT8	Outputs PLL reference control signal.

### 4-5-3 CPU (FRONT UNIT; IC1)

Pin number	Port name	Description
1	TEMP	Input port for the internal temperature.
2	BATV	Input port for low voltage detection from the connected power supply.
7	RES	Input port for the reset signal.
13, 14	SENC0, SENC1	Output ports for 5/2 tone and DTMF signals.
15	CSFT	Outputs the CPU clock shift signal.
16	DUSE	Outputs the cut-off frequency control signal to the low-pass filter (MAIN; unit IC5) for CTCSS/DTCS switching.
17	UNLK	Input port for the PLL unlock signal from the PLL IC (MAIN unit; IC4).
18	RXC	Outputs the R8V regulator circuit (MAIN unit; Q26, Q30) control signal.
19, 20	SENC0, SENC1	Output ports for 5/2 tone and DTMF signals.
21, 22	P0, P1	Input ports for key matrix.
23–25	CENO0– CENO2	Output ports for CTCSS/DTCS signals.
26, 27	P2, P3	Input ports for key matrix.
28	SCK	Outputs clock signal to the PLL IC (MAIN unit; IC4), D/A converter (MAIN unit IC6), LED driver (FRONT unit; IC4) and optional board (connect to MAIN unit; J1).
29	SO	Outputs data signal to the PLL IC (MAIN unit; IC4), D/A converter (MAIN unit; IC6), LED driver (FRONT unit; IC4) and optional board (connect to MAIN unit; J1).
30	BEEP	Output port for beep sound signal.
31	ESDA	I/O port for the data signal for the EEPROM (FRONT unit; IC3).
32	ESCL	Outputs clock signal for EEPROM (FRONT unit; IC3).
33	MMUT	Input port for the MIC mute signal from the optional board via MAIN unit, J1.
34	RMUT	Input port for the AF mute signal from the optional board via MAIN unit, J1.
36	PLST	Outputs strobe signal for PLL IC (MAIN unit; IC4).
37	DAST	Outputs strobe signal for the D/A converter IC (MAIN unit; IC6).
38	EXST	Outputs strobe signal for LED driver IC (FRONT unit; IC4).
39	EXOE	Outputs control signal for the LED driver IC (FRONT unit; IC4).
40	TMUT	Outputs the T8V regulator circuit (MAIN unit; Q25, Q29, D23) control signal.



**CPU-Continued**

Pin number	Port name	Description
41	PWON	Outputs control signal for the power switching circuit (MAIN unit; Q24, Q23).
42	NWC	Outputs IF bandwidth control signal. Low : While IF bandwidth is narrow.
43	AFON	Outputs control signal for the AF mute circuit (MAIN unit; Q35, Q36, D29). High : While AF amplifier (MAIN unit; IC8) is activated.
44–46	OPT3– OPT1	I/O ports for the optional board control signals.
47	BUSY	Outputs BUSY detection signal for the optional board via MAIN unit, J1.
48	SI	Input port for the clock signal from the optional board via MAIN unit, J1.
49	CLI	Input port for the cloning signal.
50	CLO	Output port for the cloning signal.
51	POSW	Input for the POWER switch.
52	IGSW	Input port for the remote power control signal from external connector (MAIN unit; J6).
53	NOIS	Input port for the “NOIS” signal which is used noise squelch operation from the FM IF IC (MAIN unit; IC1).
54	CIRQ	Input port for the interruption signal from the optional board via MAIN unit, J1.
55	CCS	Outputs the chip select signal for the optional board via MAIN unit, J1.
56	PTT	Input port for the PTT switch from microphone.
57	EPTT	Input port for the PTT switch from the external connector (MAIN unit; J6). Low : External PTT switch is ON.
58	HANG	Input port for the microphone hanger detection signal. Low ; Microphone on hook.
59	AFVI	Input port for the AF volume control (FRONT unit; R14). High : [VOL] is maximum clockwise.
60	CDEC	Input port for CTCSS/DTCS decoding signals.
61	SDEC	Input port for the single tone decoding signals.
62	OPV1V2	Input port for the optional board detection signal.
63	RSSI	Input port for the detection signal of the received signal strength.
64	LVIN	Input port for the PLL lock voltage.

# SECTION 5 ADJUSTMENT PROCEDURES

## 5-1 PREPARATION

When you adjust the contents on pages 5-5 and 5-6, SOFTWARE ADJUSTMENT, the optional CS-F100S ADJ ADJUSTMENT SOFTWARE (Rev. 1.0 or later), \*OPC-1122 JIG CABLE (modified OPC-1122 CLONING CABLE; see illustration below) are required.

### SYSTEM REQUIREMENTS

- IBM PC compatible computer with an RS -232C serial port (38400 bps or faster).
- Microsoft Windows 95/98 or Windows ME
- Intel Pentium 100 MHz processor or faster
- At least 16 MB RAM and 10 MB of hard disk space
- 640x480 pixel display (800x600 pixel display recommended)

IBM is a registered trademark of International Bussiness Machines Corporation in the U.S.A. and other countries. Microsoft and Windows are registered trademarks of Microsoft Corporation in the U.S.A. and other countries. Screen shots produced with permission from Microsoft Corporation. All other products or brands are registered trademarks or trademarks of their respective holders.

### ADJUSTMENT SOFTWARE INSTALLATION

- ① Boot up Windows.
  - Quit all applications when Windows is running.
- ② Insert the 'CS-F100S' into the appropriate CD drive.
- ③ Select 'Run' from the [Start] menu.
- ④ Type the setup program name using the full path name, then push [Enter] key.  
(ex. D:\CSF100SADJ\Setup.exe)
- ⑤ Follow the prompts.
- ⑥ Program group 'CS-F100S ADJ' appears in the 'Programs' folder of the [Start] menu.

### STARTING SOFTWARE ADJUSTMENT

- ① Connect IC-F110S and PC with \*OPC-1122 JIG CABLE.
- ② Turn the transceiver power ON.
- ③ Boot up Windows, and click the program group 'CS-F100S ADJ' in the 'Programs' folder of the [Start] menu, then CS-F100S ADJ's window appears.
- ④ Click 'Connect' on the CS-F100's window, then appears IC-F110S's up-to-date condition.
- ⑤ Set or modify adjustment data as desired.

### \*OPC-1122 (JIG CABLE)

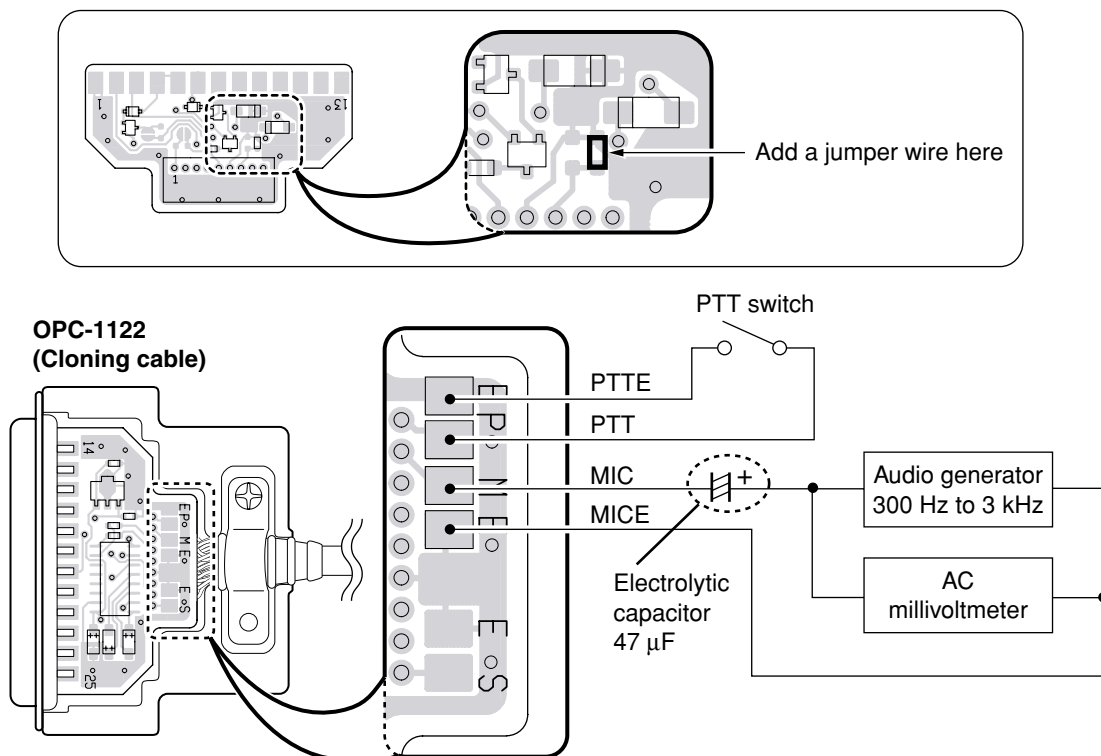

■ REQUIRED TEST EQUIPMENT

EQUIPMENT	GRADE AND RANGE	EQUIPMENT	GRADE AND RANGE
DC power supply	Output voltage : 13.2 V DC Current capacity : 15 A or more	Audio generator	Frequency range : 300–3000 Hz Measuring range : 1–500 mV
RF power meter (terminated type)	Measuring range : 1–100 W Frequency range : 100–300 MHz Impedance : 50 Ω SWR : Less than 1.2 : 1	Standard signal generator (SSG)	Frequency range : 0.1–300 MHz Output level : 0.1 μV–32 mV (–127 to –17 dBm)
Frequency counter	Frequency range : 0.1–300 MHz Frequency accuracy : ±1 ppm or better Sensitivity : 100 mV or better	Oscilloscope	Frequency range : DC–20 MHz Measuring range : 0.01–20 V
FM deviation meter	Frequency range : DC–300 MHz Measuring range : 0 to ±10 kHz	AC millivoltmeter	Measuring range : 10 mV–10 V
Digital multimeter	Input impedance : 50 kΩ/V DC or better	External speaker	Input impedance : 4 Ω Capacity : 7 W or more
		Attenuator	Power attenuation : 40 or 50 dB Capacity : 100 W or more

• Connections

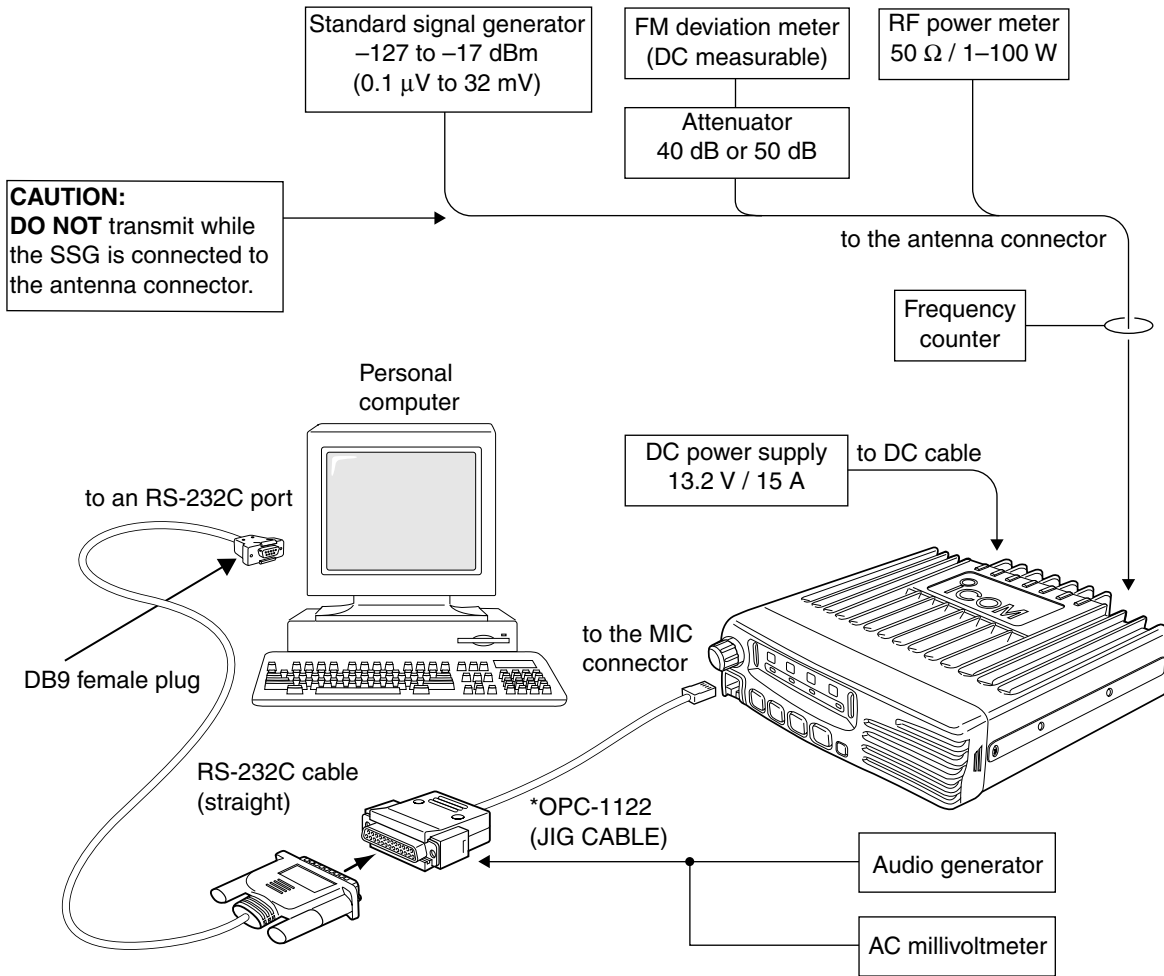

• Screen display example

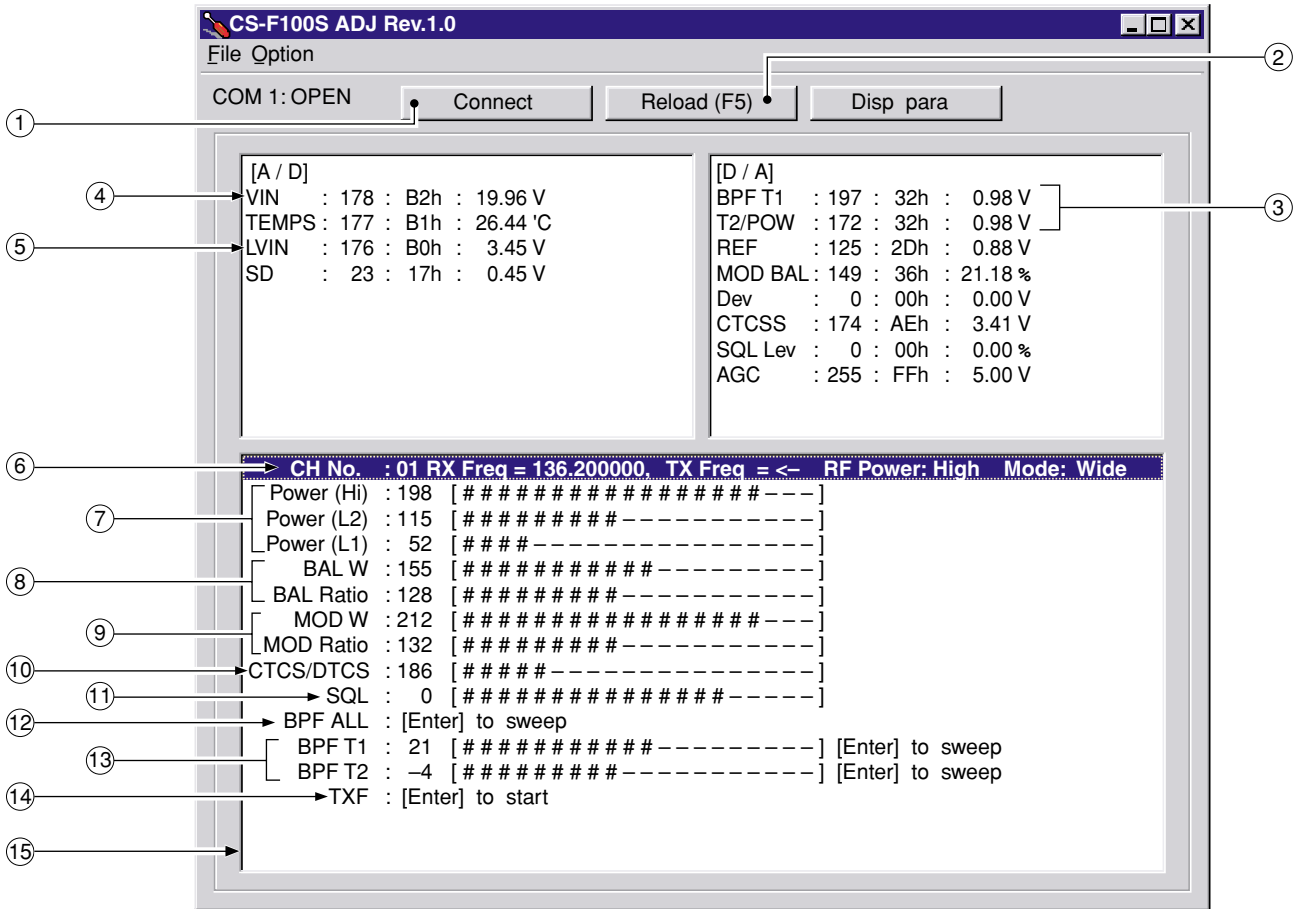

**NOTE:** The above values for settings are example only.  
Each transceiver has its own specific values for each setting.

- |                                     |   |
|-------------------------------------|---|
| ① : Transceiver's connection state  | ⑨ : FM deviation                        |
| ② : Reload adjustment data          | ⑩ : CTCSS/DTCS deviation                |
| ③ : Receive sensitivity measurement | ⑪ : Squelch level                       |
| ④ : Connected DC voltage            | ⑫ : Receive sensitivity (automatically) |
| ⑤ : PLL lock voltage                | ⑬ : Receive sensitivity (manually)      |
| ⑥ : Operating channel select        | ⑭ : Reference frequency                 |
| ⑦ : RF output power                 | ⑮ : Adjustment items                    |
| ⑧ : Modulation balance              |   |

## 5-2 PLL ADJUSTMENT

ADJUSTMENT	ADJUSTMENT CONDITIONS	MEASUREMENT		VALUE	ADJUSTMENT	
		UNIT	LOCATION		UNIT	ADJUST
PLL LOCK VOLTAGE	1 • Operating freq. : 174.000 MHz • Receiving	MAIN	Connect a digital multi-meter or an oscilloscope to the check point, "LV".	3.5 V	MAIN	C134
	2 • Output power : Low1 • Transmitting					C133
	3 • Operating freq. : 136.000 MHz • Receiving					Verify
	4 • Output power : Low1 • Transmitting					Verify

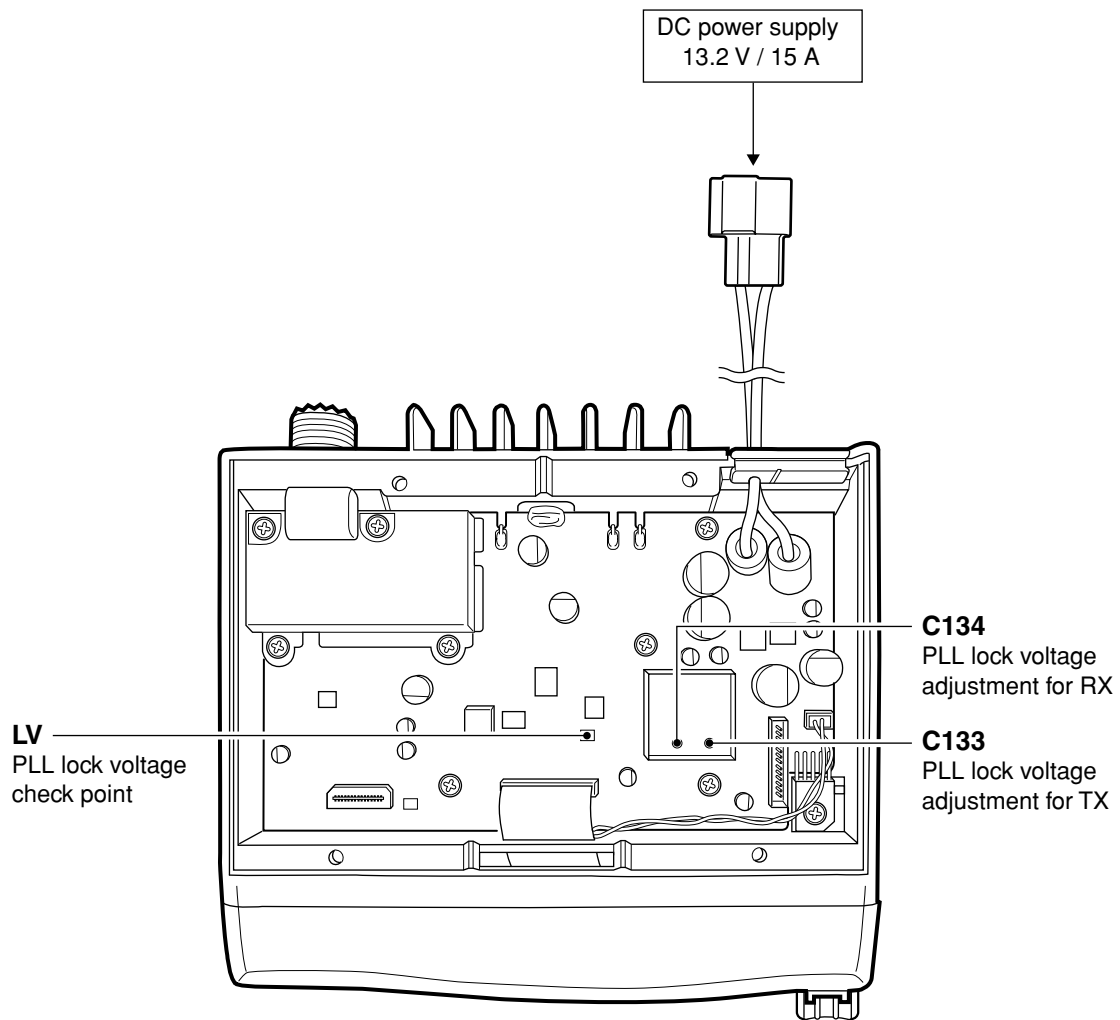

### 5-3 SOFTWARE ADJUSTMENT

Select an operation using [↑] / [↓] keys, then set specified value using [←] / [→] keys on the connected computer keyboard.

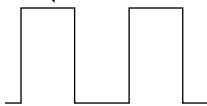
ADJUSTMENT	ADJUSTMENT CONDITION	MEASUREMENT		VALUE
		UNIT	LOCATION	
REFERENCE FREQUENCY [TXF]	1 <ul style="list-style-type: none"> <li>• Operating freq. : 174.000 MHz</li> <li>• Output power : Low1</li> <li>• Connect the RF power meter or 50 Ω dummy load to the antenna connector.</li> <li>• Transmitting</li> </ul>	Rear panel	Loosely couple a frequency counter to the antenna connector.	174.0000 MHz
OUTPUT POWER [Power (Hi)]	1 <ul style="list-style-type: none"> <li>• Operating freq. : 155.000 MHz</li> <li>• Output power : High</li> <li>• Transmitting</li> </ul>	Rear panel	Connect an RF power meter to the antenna connector.	25.0 W [25 W] 50.0 W [50 W]
[Power (L2)]	2 <ul style="list-style-type: none"> <li>• Output power : Low2</li> <li>• Transmitting</li> </ul>			10.0 W [25W] 25.0 W [50 W]
[Power (L1)]	3 <ul style="list-style-type: none"> <li>• Output power : Low1</li> <li>• Transmitting</li> </ul>			2.5 W [25W] 5.0 W [50 W]
FM DEVIATION [MOD W]	1 <ul style="list-style-type: none"> <li>• Operating freq. : 155.000 MHz</li> <li>• Output power : Low1</li> <li>• IF bandwidth : Wide</li> <li>• Connect an audio generator to the [MIC] jack through the JIG cable and set as: 1.0 kHz/40 mVrms</li> <li>• Set an FM deviation meter as: HPF : OFF LPF : 20 kHz De-emphasis: OFF Detector : (P-P)/2</li> <li>• Transmitting</li> </ul>	Rear panel	Connect an FM deviation meter to the antenna connector through the attenuator.	±4.1 kHz [N/W] ±3.3 kHz [N/M]
[MOD Ratio]	2 <ul style="list-style-type: none"> <li>• IF bandwidth : Narrow</li> <li>• Transmitting</li> </ul>			±2.1 kHz
MODULATION BALLANCE [BAL W]	1 <ul style="list-style-type: none"> <li>• Set to the DTCS set channel, and push [Connect] on the adjustment software.</li> <li>• Operating freq. : 174.000 MHz</li> <li>• Output power : Low1</li> <li>• Transmitting</li> </ul>	Rear panel	Connect an FM deviation meter with an oscilloscope to the antenna connector through an attenuator.	Set to square wave form 
[BAL Ratio]	2 <ul style="list-style-type: none"> <li>• IF bandwidth : Narrow</li> <li>• Transmitting</li> </ul>			
CTCSS/DTCS DEVIATION [CTCS/DTCS]	1 <ul style="list-style-type: none"> <li>• Operating freq. : 155.000 MHz</li> <li>• Output power : Low1</li> <li>• IF bandwidth : Wide</li> <li>• CTCSS : 88.5 Hz</li> <li>• DTCS code : 007</li> <li>• Set the FM deviation meter as: HPF : OFF LPF : 20 kHz De-emphasis: OFF Detector : (P-P)/2</li> <li>• No audio applied to the [MIC] connector.</li> <li>• Transmitting</li> </ul>	Rear panel	Connect an FM deviation meter to the antenna connector through the attenuator.	±0.68 kHz [N/W] ±0.56 kHz [N/M]

## SOFTWARE ADJUSTMENT – continued

Select an operation using [↑] / [↓] keys, then set specified value using [←] / [→] keys on the connected computer keyboard.

ADJUSTMENT	ADJUSTMENT CONDITION	MEASUREMENT		VALUE	
		UNIT	LOCATION		
RX SENSITIVITY [BPF T1], [BPF T2]	1	<ul style="list-style-type: none"> <li>Operating freq. : 136.000 MHz</li> <li>IF bandwidth : Wide</li> <li>Connect a standard signal generator to the antenna connector and set as:                             <ul style="list-style-type: none"> <li>Frequency : 136.000 MHz</li> <li>Level : 10 μV* (-87 dBm)</li> <li>Modulation : 1 kHz</li> <li>Deviation : ±3.5 kHz [N/W]</li> <li>                  ±2.8 kHz [N/M]</li> </ul> </li> <li>Receiving</li> </ul>	MAIN	Connect a SINAD meter with a 4 Ω load to the external [SP] jack.	Minimum distortion level
	<p><b>CONVENIENT:</b> The BPF T1–BPF T2 can be adjusted automatically.</p> <p>①-1: Set the cursor to “BPF ALL” on the adjustment program and then push [ENTER] key.</p> <p>①-2: The connected PC tunes BPF T1, BPF T2 to peak levels.</p> <p style="text-align: center;">or</p> <p>②-1: Set the cursor to BPF T1 or BPF T2 as desired.</p> <p>②-2: Push [ENTER] key to start tuning.</p> <p>②-3: Repeat ②-1 and ②-2 to perform additional BPF tuning.</p>				
SQUELCH LEVEL [SQL]	1	<ul style="list-style-type: none"> <li>Operating freq. : 155.000 MHz</li> <li>IF bandwidth : Narrow</li> <li>Connect an SSG to the antenna connector and set as:                             <ul style="list-style-type: none"> <li>Frequency : 155.000 MHz</li> <li>Level : 0.2 μV* (-121 dBm)</li> <li>Modulation : 1 kHz</li> <li>Deviation : ±1.75 kHz</li> </ul> </li> <li>Receiving</li> </ul>	Rear panel	Connect a SINAD meter with a 4 Ω load to the external [SP] jack.	Set “SQL level” to close squelch.  Then set “SQL level” at the point where the audio signals just appears.

\*The output level of the standard signal generator (SSG) is indicated as the SSG’s open circuit.

## 5-4 TRIMMER ADJUSTMENT

- Make this adjustment if necessary (For example, when beep sound is too loud or too soft).
- **BE CAREFUL!**: 5-tone calling beep sound becomes loud or soft when beep volume adjusts to loud or soft.

ADJUSTMENT	ADJUSTMENT CONDITIONS	MEASUREMENT		ADJUSTMENT	
		UNIT	LOCATION	UNIT	ADJUST
BEEP VOLUME	1 <ul style="list-style-type: none"> <li>• Operating freq. : Any</li> <li>• Receiving</li> </ul>	FRONT	Push any button except [POWER] switch, then verify the beep volume level.	FRONT	R59

### • FRONT PANEL

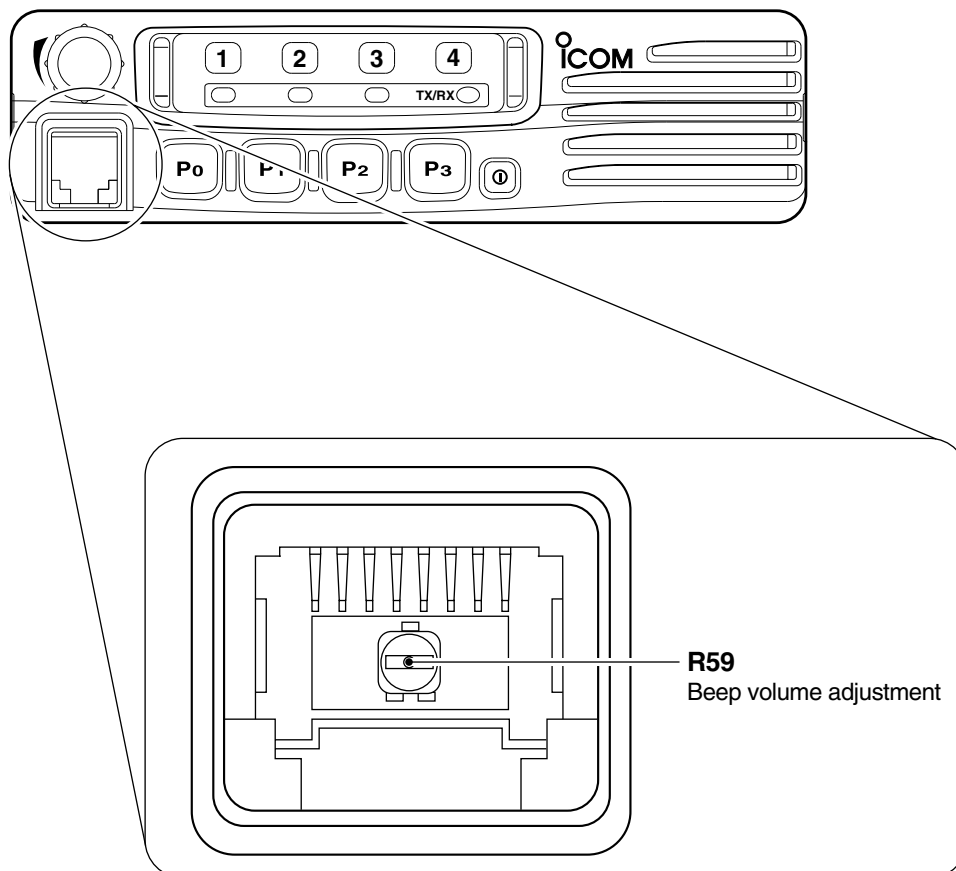



# SECTION 6 PARTS LIST

## [FRONT UNIT]

REF NO.	ORDER NO.	DESCRIPTION	
IC1	1140010890	S.IC	HD6433687A05FP
IC2	1110005770	S.IC	S-80942CNMC-G9C-T2
IC3	1130010390	S.IC	HN58X2416T1
IC4	1130009670	S.IC	BU2092FV-E2
IC5	1110005340	S.IC	NJM12902V-TE1
Q1	1530002060	S.TRANSISTOR	2SC4081 T106 R
Q2	1590001050	S.TRANSISTOR	DTC114TUA T106
Q3	1590000430	S.TRANSISTOR	DTC144EUA T106
D1	1790000950	S.ZENER	MA8056-M (TX)
D2	1790000950	S.ZENER	MA8056-M (TX)
D3	1790000950	S.ZENER	MA8056-M (TX)
D4	1790000620	S.DIODE	MA77 (TX)
D5	1790001250	S.DIODE	MA2S111-(TX)
X1	6050009520	S.XTAL	CR-520 (19.6608 MHz)
L1	6200003640	S.COIL	MLF1608E 100K-T
L2	6200001980	S.COIL	NL 252018T-1R0J
R1	7030008400	S.RESISTOR	ERJ2GEJ 182 X (1.8 kΩ)
R2	7030009280	S.RESISTOR	ERJ2GE
R3	7030005120	S.RESISTOR	ERJ2GEJ 102 X (1 kΩ)
R4	7030005120	S.RESISTOR	ERJ2GEJ 102 X (1 kΩ)
R5	7030005120	S.RESISTOR	ERJ2GEJ 102 X (1 kΩ)
R6	7030005010	S.RESISTOR	ERJ2GEJ 681 X (680 Ω)
R7	7030005010	S.RESISTOR	ERJ2GEJ 681 X (680 Ω)
R8	7030005010	S.RESISTOR	ERJ2GEJ 681 X (680 Ω)
R9	7030005010	S.RESISTOR	ERJ2GEJ 681 X (680 Ω)
R10	7030005030	S.RESISTOR	ERJ2GEJ 152 X (1.5 kΩ)
R11	7030008370	S.RESISTOR	ERJ2GEJ 561 X (560 Ω)
R12	7030009280	S.RESISTOR	ERJ2GE
R13	7030005050	S.RESISTOR	ERJ2GEJ 103 X (10 kΩ)
R14	7210003020	VARIABLE	EVU-F2KFK1 B14 (10KB)
R15	7030005120	S.RESISTOR	ERJ2GEJ 102 X (1 kΩ)
R16	7030005120	S.RESISTOR	ERJ2GEJ 102 X (1 kΩ)
R17	7030005090	S.RESISTOR	ERJ2GEJ 104 X (100 kΩ)
R18	7030005090	S.RESISTOR	ERJ2GEJ 104 X (100 kΩ)
R19	7030005090	S.RESISTOR	ERJ2GEJ 104 X (100 kΩ)
R20	7030008300	S.RESISTOR	ERJ2GEJ 184 X (180 kΩ)
R21	7030005720	S.RESISTOR	ERJ2GEJ 563 X (56 kΩ)
R22	7030005220	S.RESISTOR	ERJ2GEJ 223 X (22 kΩ)
R23	7030005240	S.RESISTOR	ERJ2GEJ 473 X (47 kΩ)
R24	7030005240	S.RESISTOR	ERJ2GEJ 473 X (47 kΩ)
R25	7030005220	S.RESISTOR	ERJ2GEJ 223 X (22 kΩ)
R26	7030005240	S.RESISTOR	ERJ2GEJ 473 X (47 kΩ)
R27	7030005240	S.RESISTOR	ERJ2GEJ 473 X (47 kΩ)
R28	7030005040	S.RESISTOR	ERJ2GEJ 472 X (4.7 kΩ)
R29	7030005220	S.RESISTOR	ERJ2GEJ 223 X (22 kΩ)
R30	7030005110	S.RESISTOR	ERJ2GEJ 224 X (220 kΩ)
R31	7030005090	S.RESISTOR	ERJ2GEJ 104 X (100 kΩ)
R32	7030005240	S.RESISTOR	ERJ2GEJ 473 X (47 kΩ)
R33	7030005220	S.RESISTOR	ERJ2GEJ 223 X (22 kΩ)
R34	7030005220	S.RESISTOR	ERJ2GEJ 223 X (22 kΩ)
R35	7030005070	S.RESISTOR	ERJ2GEJ 683 X (68 kΩ)
R36	7030005070	S.RESISTOR	ERJ2GEJ 683 X (68 kΩ)
R37	7030005070	S.RESISTOR	ERJ2GEJ 683 X (68 kΩ)
R38	7030005070	S.RESISTOR	ERJ2GEJ 683 X (68 kΩ)
R39	7030005070	S.RESISTOR	ERJ2GEJ 683 X (68 kΩ)
R40	7030005240	S.RESISTOR	ERJ2GEJ 473 X (47 kΩ)
R41	7030005050	S.RESISTOR	ERJ2GEJ 103 X (10 kΩ)
R42	7030007350	S.RESISTOR	ERJ2GEJ 393 X (39 kΩ)
R43	7030005060	S.RESISTOR	ERJ2GEJ 333 X (33 kΩ)
R44	7030005100	S.RESISTOR	ERJ2GEJ 154 X (150 kΩ)
R45	7030005530	S.RESISTOR	ERJ2GEJ 100 X (10 Ω)
R46	7030005160	S.RESISTOR	ERJ2GEJ 105 X (1 MΩ)
R47	7030008010	S.RESISTOR	ERJ2GEJ 123 X (12 kΩ)
R48	7030008010	S.RESISTOR	ERJ2GEJ 123 X (12 kΩ)
R49	7030008010	S.RESISTOR	ERJ2GEJ 123 X (12 kΩ)
R50	7410001130	S.ARRAY	EXB28V102JX

## [FRONT UNIT]

REF NO.	ORDER NO.	DESCRIPTION	
R51	7030005090	S.RESISTOR	ERJ2GEJ 104 X (100 kΩ)
R52	7030005120	S.RESISTOR	ERJ2GEJ 102 X (1 kΩ)
R53	7410001130	S.ARRAY	EXB28V102JX
R54	7410001130	S.ARRAY	EXB28V102JX
R55	7410000770	S.ARRAY	EXB-V4V 102JV (1 kΩ)
R56	7410001130	S.ARRAY	EXB28V102JX
R57	7030005160	S.RESISTOR	ERJ2GEJ 105 X (1 MΩ)
R58	7030005050	S.RESISTOR	ERJ2GEJ 103 X (10 kΩ)
R59	7310002740	S.TRIMMER	RV-150 (RH03A3A14X0FC) 103
R60	7030005090	S.RESISTOR	ERJ2GEJ 104 X (100 kΩ)
R61	7030005090	S.RESISTOR	ERJ2GEJ 104 X (100 kΩ)
R62	7030005090	S.RESISTOR	ERJ2GEJ 104 X (100 kΩ)
R63	7030005090	S.RESISTOR	ERJ2GEJ 104 X (100 kΩ)
R64	7030005090	S.RESISTOR	ERJ2GEJ 104 X (100 kΩ)
R65	7030005090	S.RESISTOR	ERJ2GEJ 104 X (100 kΩ)
R66	7030005090	S.RESISTOR	ERJ2GEJ 104 X (100 kΩ)
R67	7030005050	S.RESISTOR	ERJ2GEJ 103 X (10 kΩ)
R68	7030005050	S.RESISTOR	ERJ2GEJ 103 X (10 kΩ)
R69	7030005090	S.RESISTOR	ERJ2GEJ 104 X (100 kΩ)
R70	7030005030	S.RESISTOR	ERJ2GEJ 152 X (1.5 kΩ)
R71	7030005120	S.RESISTOR	ERJ2GEJ 102 X (1 kΩ)
R72	7030005030	S.RESISTOR	ERJ2GEJ 152 X (1.5 kΩ)
R73	7030006610	S.RESISTOR	ERJ2GEJ 394 X (390 kΩ)
C1	4030016930	S.CERAMIC	ECJ0EB1A104K
C2	4030017420	S.CERAMIC	ECJ0EC1H470J
C3	4030017420	S.CERAMIC	ECJ0EC1H470J
C4	4030017420	S.CERAMIC	ECJ0EC1H470J
C5	4030017420	S.CERAMIC	ECJ0EC1H470J
C6	4030017420	S.CERAMIC	ECJ0EC1H470J
C7	4030017420	S.CERAMIC	ECJ0EC1H470J
C8	4030017460	S.CERAMIC	ECJ0EB1E102K
C9	4030017460	S.CERAMIC	ECJ0EB1E102K
C10	4030017460	S.CERAMIC	ECJ0EB1E102K
C11	4030017420	S.CERAMIC	ECJ0EC1H470J
C12	4030017460	S.CERAMIC	ECJ0EB1E102K
C14	4030017460	S.CERAMIC	ECJ0EB1E102K
C15	4030017900	S.CERAMIC	ECJ0EB1C123K
C16	4030016930	S.CERAMIC	ECJ0EB1A104K
C17	4030017740	S.CERAMIC	ECJ0EB1E821K
C19	4030016930	S.CERAMIC	ECJ0EB1A104K
C20	4030018110	S.CERAMIC	ECJ0EB1H272K
C21	4030018240	S.CERAMIC	ECJ0EB1E562K
C22	4030017710	S.CERAMIC	ECJ0EC1H181J
C23	4030018090	S.CERAMIC	ECJ0EB1C822K
C24	4030017510	S.CERAMIC	ECJ0EC1H680J
C25	4030016790	S.CERAMIC	ECJ0EB1C103K
C26	4030016930	S.CERAMIC	ECJ0EB1A104K
C27	4030017450	S.CERAMIC	ECJ0EB1E271K
C28	4030016930	S.CERAMIC	ECJ0EB1A104K
C29	4550006050	S.TANTALUM	TEMSVA OJ 106M8L
C30	4030017030	S.CERAMIC	ECJ0EB1A273K
C31	4030017400	S.CERAMIC	ECJ0EC1H220J
C32	4030017640	S.CERAMIC	ECJ0EC1H150J
C33	4030017510	S.CERAMIC	ECJ0EC1H680J
C34	4030017730	S.CERAMIC	ECJ0EB1E471K
C35	4030016930	S.CERAMIC	ECJ0EB1A104K
C36	4030016930	S.CERAMIC	ECJ0EB1A104K
C38	4030018390	S.CERAMIC	ECJ0EB1A563K
C50	4030017420	S.CERAMIC	ECJ0EC1H470J
C54	4030017420	S.CERAMIC	ECJ0EC1H470J
C74	4030017420	S.CERAMIC	ECJ0EC1H470J
C75	4030016930	S.CERAMIC	ECJ0EB1A104K
C76	4030016930	S.CERAMIC	ECJ0EB1A104K
C77	4030016950	S.CERAMIC	ECJ0EB1A473K
C78	4030017460	S.CERAMIC	ECJ0EB1E102K
C82	4030017460	S.CERAMIC	ECJ0EB1E102K
C84	4030017460	S.CERAMIC	ECJ0EB1E102K
C85	4030017460	S.CERAMIC	ECJ0EB1E102K
C86	4030017460	S.CERAMIC	ECJ0EB1E102K
C87	4030017460	S.CERAMIC	ECJ0EB1E102K
C88	4030017460	S.CERAMIC	ECJ0EB1E102K
J1	6450002210	CONNECTOR	3017-8821

Ⓐ: IC-F110S

Ⓒ: IC-F110S for [EUR]

Ⓔ: Narrow/middle version

Ⓑ: IC-F120S/F111S

Ⓓ: Narrow/wide version

S.=Surface mount

**[FRONT UNIT]**

REF NO.	ORDER NO.	DESCRIPTION	
J2	6510022470	S.CONNECTOR	40FLT-SM1-TB
DS1	5040002670	S.LED	CL-165HR/YG
DS2	5040002310	S.LED	SML-311YTT86
DS3	5040002310	S.LED	SML-311YTT86
DS4	5040002310	S.LED	SML-311YTT86
DS5	5040002310	S.LED	SML-311YTT86
DS6	5040002310	S.LED	SML-311YTT86
DS7	5040002310	S.LED	SML-311YTT86
DS8	5040002310	S.LED	SML-311YTT86
DS9	5040002310	S.LED	SML-311YTT86
DS10	5040002310	S.LED	SML-311YTT86
SP1	2510001220	SPEAKER	C052SB500-13
W1	8900010500	CABLE	OPC-1046
W2	8900011800	CABLE	OPC-1199
EP1	0910055554	PCB	B 5872D

**[MAIN UNIT]**

REF NO.	ORDER NO.	DESCRIPTION	
IC1	1110003490	S.IC	TA31136FN (D,EL)
IC2	1110002750	S.IC	TA75S01F (TE85R)
IC3	1150002040	IC	RA30H1317M-01
	1150002100	IC	S-AV32 (I)
IC4	1140005990	S.IC	MB15A02PFV1-G-BND-ER
IC5	1110005330	S.IC	NJM12904V-TE1
IC6	1190000350	S.IC	M62363FP-650C
IC8	1110003090	IC	LA4425A
IC9	1180001250	S.IC	TA7808F (TE16L)
IC10	1180000970	S.IC	AN78L05M-(E1)
IC14	1130008090	S.IC	BU4066BCFV-E1
IC15	1110002750	S.IC	TA75S01F (TE85R)
IC16	1110005340	S.IC	NJM12902V-TE1
Q1	1560000840	S.FET	2SK1829 (TE85R)
Q2	1580000730	S.FET	3SK293 (TE85L)
Q3	1580000760	S.FET	3SK299-T1 U73
Q4	1530002600	S.TRANSISTOR	2SC4215-O (TE85R)
Q5	1590000430	S.TRANSISTOR	DTC144EUA T106
Q8	1530000371	S.TRANSISTOR	2SC3356-T1B R25
Q10	1530003310	S.TRANSISTOR	2SC5107-O (TE85R)
Q11	1530003310	S.TRANSISTOR	2SC5107-O (TE85R)
Q12	1530003310	S.TRANSISTOR	2SC5107-O (TE85R)
Q13	1530002920	S.TRANSISTOR	2SC4226-T1 R25
Q14	1530002920	S.TRANSISTOR	2SC4226-T1 R25
Q15	1590001400	S.TRANSISTOR	XP1214 (TX)
Q16	1590000430	S.TRANSISTOR	DTC144EUA T106
Q17	1530002850	S.TRANSISTOR	2SC4116-BL (TE85R)
Q18	1560000540	S.FET	2SK880-Y (TE85R)
Q19	1530002600	S.TRANSISTOR	2SC4215-O (TE85R)
Q20	1530002850	S.TRANSISTOR	2SC4116-BL (TE85R)
Q23	1550000020	S.FET	2SJ377 (TE16R)
Q24	1590000430	S.TRANSISTOR	DTC144EUA T106
Q25	1540000550	S.TRANSISTOR	2SD1664 T100Q
Q26	1510000920	S.TRANSISTOR	2SA1577 T106 Q
Q27	1510000920	S.TRANSISTOR	2SA1577 T106 Q
Q28	1590001190	S.TRANSISTOR	XP6501-(TX) .AB
Q29	1590001050	S.TRANSISTOR	DTC114TUA T106
Q30	1590000430	S.TRANSISTOR	DTC144EUA T106
Q31	1590001450	S.FET	2SJ144-GR (TE85R)
Q33	1590000430	S.TRANSISTOR	DTC144EUA T106
Q34	1530002850	S.TRANSISTOR	2SC4116-BL (TE85R)
Q35	1590000990	S.TRANSISTOR	DTC363EK T146
Q36	1590000430	S.TRANSISTOR	DTC144EUA T106
D1	1790001210	S.DIODE	1SS375-TL
D2	1750000510	S.DIODE	UM9401F

**[MAIN UNIT]**

REF NO.	ORDER NO.	DESCRIPTION	
D3	1710001060	DIODE	XB15A407
D4	1750000720	S.VARICAP	HVC375BTRF
D5	1790000620	S.DIODE	MA77 (TX)
D6	1790000620	S.DIODE	MA77 (TX)
D7	1790001240	S.DIODE	MA2S728-(TX)
D8	1750000720	S.VARICAP	HVC375BTRF
D9	1750000710	S.VARICAP	HVC350BTRF
D10	1750000710	S.VARICAP	HVC350BTRF
D11	1790001210	S.DIODE	1SS375-TL
D12	1790001210	S.DIODE	1SS375-TL
D14	1790000620	S.DIODE	MA77 (TX)
D15	1790000620	S.DIODE	MA77 (TX)
D16	1750000770	S.VARICAP	HVC376BTRF
D18	1720000470	S.VARICAP	1SV239 (TPH3)
D20	1790001250	S.DIODE	MA2S111-(TX)
D21	1750000830	S.VARICAP	HVC362TRF
D22	1790000700	DIODE	DSA3A1
D23	1750000370	S.DIODE	DA221 TL
D26	1790001250	S.DIODE	MA2S111-(TX)
D27	1790001250	S.DIODE	MA2S111-(TX)
D28	1790001240	S.DIODE	MA2S728-(TX)
D29	1790001250	S.DIODE	MA2S111-(TX)
D30	1750000520	S.DIODE	DAN222TL
D31	1750000770	S.VARICAP	HVC376BTRF
D33	1750000770	S.VARICAP	HVC376BTRF
D34	1750000770	S.VARICAP	HVC376BTRF
D37	1790001250	S.DIODE	MA2S111-(TX)
D38	1750000510	S.DIODE	UM9401F
D40	1750000520	S.DIODE	DAN222TL
D41	1790000620	S.DIODE	MA77 (TX)
D42	1750000370	S.DIODE	DA221 TL
D43	1790001250	S.DIODE	MA2S111-(TX)
F11	2030000150	S.MONOLITH	FL-335 (46.350 MHz)
F12	2020001840	CERAMIC	ALFYM450F=K
F13	2040001440	S.LC	NFE31PT152Z1E9L
F14	2040001440	S.LC	NFE31PT152Z1E9L
F15	2040001440	S.LC	NFE31PT152Z1E9L
X1	6070000190	S.DISCRIMINATOR	CDBC450KCA24-R0
X2	6050011510	S.XTAL	CR-740 (15.300 MHz)
L1	6200010050	S.COIL	AS080547-47N
L2	6200010050	S.COIL	AS080547-47N
L3	6200010050	S.COIL	AS080547-47N
L4	6200010430	S.COIL	0.50-2.0-6TL
L5	6200010420	S.COIL	FHW1210HC 1R0JGT
L6	6200010400	S.COIL	ELJRE 39NJ 39N
L7	6200008090	S.COIL	LQW2BHN68NJ01L
L8	6200008090	S.COIL	LQW2BHN68NJ01L
L9	6200007750	S.COIL	LQW2BHN56NJ01L
L10	6200004660	S.COIL	MLF1608A 1R8K-T
L11	6200007750	S.COIL	LQW2BHN56NJ01L
L12	6200009180	S.COIL	ELJRE R10J-F3
L13	6200003330	S.COIL	NL 322522T-1R0J-3
L16	6200010050	S.COIL	AS080547-47N
L18	6200009170	S.COIL	ELJRE 47NJ-F2
L19	6200009150	S.COIL	ELJRE 82NJ-F3
L21	6200009150	S.COIL	ELJRE 82NJ-F3
L22	6200009160	S.COIL	ELJRE 68NJ-F3
L25	6200009460	S.COIL	0.25-1.9-7TL 67N
L26	6200008390	S.COIL	0.25-1.9-9TL
L27	6200002000	S.COIL	NL 252018T-3R3J
L28	6200002000	S.COIL	NL 252018T-3R3J
L29	6200004660	S.COIL	MLF1608A 1R8K-T
L31	6200007750	S.COIL	LQW2BHN56NJ01L
L32	6200010390	S.COIL	ELJRE 33NJ-F3
L33	6200004480	S.COIL	MLF1608D R82K-T
L35	6200003540	S.COIL	MLF1608D R22K-T
L37	6200003640	S.COIL	MLF1608E 100K-T
L38	6200008190	S.COIL	0.25-1.9-8TL 80N
L39	6200008150	S.COIL	0.35-1.6-7TL 44N
L41	6200009160	S.COIL	ELJRE 68NJ-F3
R1	7030000620	S.RESISTOR	MCR10EZJH 100 kΩ
R2	7030000220	S.RESISTOR	MCR10EZJH 47 Ω (470)
R3	7030000220	S.RESISTOR	MCR10EZJH 47 Ω (470)
R4	7030003370	S.RESISTOR	ERJ3GGEYJ 271 V (270 Ω)

Ⓐ: IC-F110S

Ⓑ: IC-F120S/F111S

Ⓒ: IC-F110S for [EUR]

Ⓓ: Narrow/wide version

Ⓔ: Narrow/middle version

S.=Surface mount







[MAIN UNIT]

REF NO.	ORDER NO.	DESCRIPTION	
C305	4030007100	S.CERAMIC	C1608 CH 1H 560J-T
C306	4030009910	S.CERAMIC	C1608 CH 1H 040B-T
C307	4030006980	S.CERAMIC	C1608 CH 1H 070D-T
C308	4030009530	S.CERAMIC	C1608 CH 1H 030B-T
C309	4030006900	S.CERAMIC	C1608 JB 1H 103K-T
C310	4030006860	S.CERAMIC	C1608 JB 1H 102K-T
C311	4030006860	S.CERAMIC	C1608 JB 1H 102K-T
C312	4030011600	S.CERAMIC	C1608 JB 1E 104K-T
C314	4030006900	S.CERAMIC	C1608 JB 1H 103K-T
C315	4030008880	S.CERAMIC	C1608 JB 1H 223K-T
C316	4030009490	S.CERAMIC	C1608 JB 1H 821K-T
C317	4030009490	S.CERAMIC	C1608 JB 1H 821K-T
C318	4030011600	S.CERAMIC	C1608 JB 1E 104K-T
C320	4030008910	S.CERAMIC	C1608 JB 1H 393K-T
C321	4030011600	S.CERAMIC	C1608 JB 1E 104K-T
C322	4030006900	S.CERAMIC	C1608 JB 1H 103K-T
C324	4030011340	S.CERAMIC	C1608 CH 1H 471J-T
C325	4030006860	S.CERAMIC	C1608 JB 1H 102K-T
C327	4510004630	S.ELECTROLYTIC	ECEV1CA100SR
C330	4550006170	S.TANTALUM	ECST1AY225R
C331	4030006860	S.CERAMIC	C1608 JB 1H 102K-T
C332	4550006700	S.TANTALUM	ECST1AY106R
C333	4030007090	S.CERAMIC	C1608 CH 1H 470J-T
C335	4030006860	S.CERAMIC	C1608 JB 1H 102K-T
C337	4030006860	S.CERAMIC	C1608 JB 1H 102K-T
C339	4030009550	S.CERAMIC	C1608 CH 1H 2R5B-T
C342	4550006410	S.TANTALUM	ECST1VY334R
C343	4030006900	S.CERAMIC	C1608 JB 1H 103K-T
C348	4030006860	S.CERAMIC	C1608 JB 1H 102K-T
C349	4030011600	S.CERAMIC	C1608 JB 1E 104K-T
C350	4030017490	S.CERAMIC	C1608 JB 1A 105K-T
C351	4030008920	S.CERAMIC	C1608 JB 1H 473K-T
C352	4510005750	S.ELECTROLYTIC	ECEV1EA220SP
C353	4030006980	S.CERAMIC	C1608 CH 1H 070D-T
C355	4030011770	S.CERAMIC	C1608 CH 1H 060B-T
C356	4030011770	S.CERAMIC	C1608 CH 1H 060B-T
C357	4030011600	S.CERAMIC	C1608 JB 1E 104K-T
C359	4030017490	S.CERAMIC	C1608 JB 1A 105K-T
C360	4030011770	S.CERAMIC	C1608 CH 1H 060B-T
C361	4030006860	S.CERAMIC	C1608 JB 1H 102K-T
C362	4030011600	S.CERAMIC	C1608 JB 1E 104K-T
C363	4030006860	S.CERAMIC	C1608 JB 1H 102K-T
C364	4030006900	S.CERAMIC	C1608 JB 1H 103K-T
C365	4030009540	S.CERAMIC	C1608 CH 1H 1R5B-T
C366	4030009530	S.CERAMIC	C1608 CH 1H 030B-T
C367	4030011600	S.CERAMIC	C1608 JB 1E 104K-T
C368	4030007130	S.CERAMIC	C1608 CH 1H 101J-T
C370	4030007130	S.CERAMIC	C1608 CH 1H 101J-T
C375	4030009570	S.CERAMIC	C1608 CH 1H 0R3B-T
C376	4030006860	S.CERAMIC	C1608 JB 1H 102K-T
C390	4030011170	S.CERAMIC	GRM31M2C2H180JV01L
C392	4030011120	S.CERAMIC	GRM31M2C2H100JV01L
C393	4030011120	S.CERAMIC	GRM31M2C2H100JV01L
C401	4030011340	S.CERAMIC	C1608 CH 1H 471J-T
C402	4030011340	S.CERAMIC	C1608 CH 1H 471J-T
C405	4030006860	S.CERAMIC	C1608 JB 1H 102K-T
C406	4030011340	S.CERAMIC	C1608 CH 1H 471J-T
C407	4030007090	S.CERAMIC	C1608 CH 1H 470J-T
C408	4030006860	S.CERAMIC	C1608 JB 1H 102K-T
C409	4030007090	S.CERAMIC	C1608 CH 1H 470J-T
C410	4030007090	S.CERAMIC	C1608 CH 1H 470J-T
C411	4030011340	S.CERAMIC	C1608 CH 1H 471J-T
C412	4030006860	S.CERAMIC	C1608 JB 1H 102K-T
C413	4030011340	S.CERAMIC	C1608 CH 1H 471J-T
C424	4030007130	S.CERAMIC	C1608 CH 1H 101J-T
C426	4030007130	S.CERAMIC	C1608 CH 1H 101J-T
C427	4030007170	S.CERAMIC	C1608 CH 1H 221J-T
C428	4030007130	S.CERAMIC	C1608 CH 1H 101J-T
C429	4030010240	S.CERAMIC	C1608 JB 1H 391K-T
C430	4030006860	S.CERAMIC	C1608 JB 1H 102K-T
C431	4030007130	S.CERAMIC	C1608 CH 1H 101J-T
C432	4030007130	S.CERAMIC	C1608 CH 1H 101J-T
C433	4030007130	S.CERAMIC	C1608 CH 1H 101J-T
J1	6510018430	S.CONNECTOR	AXN330C038P
J2	6510022470	S.CONNECTOR	40FLT-SM1-TB
J4	6450000140	CONNECTOR	HSJ0807-01-010
J6	6510019250	S.CONNECTOR	B11B-ZR-SM3-TF
J7	6510014960	S.CONNECTOR	B2B-ZR-SM3-TF

Ⓐ: IC-F110S

Ⓒ: IC-F110S for [EUR]

Ⓔ: Narrow/middle version

Ⓑ: IC-F120S/F111S

Ⓓ: Narrow/wide version

[MAIN UNIT]

REF NO.	ORDER NO.	DESCRIPTION	
W1	7120000470	JUMPER	ERDS2T0
W2	8900011861	CABLE	OPC-1195A
W4	7030003860	S.JUMPER	ERJ3GE JPW V
W5	7030003860	S.JUMPER	ERJ3GE JPW V
EP1	6910013370	S.BEAD	BLM18BB221SN1D
EP2	6910011560	BEAD	HF70BB4.5X5X1.6
EP3	6910011560	BEAD	HF70BB4.5X5X1.6
EP4	6910010280	BEAD	HF70BB9.5X10.4X4.9
EP5	6910010280	BEAD	HF70BB9.5X10.4X4.9
EP6	0910055545	PCB	B 5873E

S.=Surface mount

# SECTION 7 MECHANICAL PARTS

## [CHASSIS PARTS]

REF. NO.	ORDER NO.	DESCRIPTION	QTY.
J1	6510004880	Connector MR-DS-E 01	1
MP1	8010019060	2601 chassis [25W]	1
	8010019130	2601 long chassis [50W]	1
MP2	8110007820	2601 cover	1
MP3	8810008660	Screw PH BT M3 × 8 NI-ZU	8
MP4	8810008660	Screw PH BT M3 × 8 NI-ZU	2
MP5	8810008660	Screw PH BT M3 × 8 NI-ZU	2
MP6	8810008660	Screw PH BT M3 × 8 NI-ZU	1
MP7	8810009990	Screw PH BT M3 × 8 ZK	4
MP8	8810009990	Screw PH BT M3 × 8 ZK	2
MP10	8930058990	Shield sponge (V) [EUR] only	1

## [FRONT UNIT]

REF. NO.	ORDER NO.	DESCRIPTION	QTY.
R14	7210003020	Variable resistor EVU-F2KFK1B14	1
SP1	2510001220	Speaker C052SB500-13	1
J1	6450002210	Connector 3017-8821	1
W1	8900010500	Cable OPC-1046	1
MP1	8210019080	2601 front panel	1
MP2	8930058340	2601 front key	1
MP3	8310054410	2601 front plate	1
MP4	8210019090	2601 reflector	1
MP5	8610011180	Knob N292	1
MP6	8610007420	Knob spring No.6601	1
MP7	8810008660	Screw PH BT M3 × 8 NI-ZU	2
MP8	8510014930	2601 earth plate	1
MP9	8930059000	2601 SP net	1
MP10	8810008660	Screw PH BT M3 × 8 NI-ZU	2

## [MAIN UNIT]

REF. NO.	ORDER NO.	DESCRIPTION	QTY.
J4	6450000140	Connector HSJ0807-01-010	1
W2	8900011861	Cable OPC-1195A	1
MP1	8510002280	VCO shield plate (A)	1
MP2	8930058840	Shield sponge (T) [25W] only	1
MP3	8930058840	Shield sponge (T) [USA],[GEN] only	1
MP4	8510014940	2601 VCO case	1
MP5	8510014950	2601 VCO cover	1
MP6	8510014910	2601 filter case	1
MP7	8510014920	2601 M-plate [25W-GEN]	1
	8510015110	2602 M-plate [Other]	1
MP9	8930058990	Shield sponge (V)	1
MP10	8930059380	Shield sponge (X) [EUR] only	1

## [ACCESSORIES]

REF. NO.	ORDER NO.	DESCRIPTION	QTY.
MC1	0800005780	Microphone HM-100N	1
W1	8900011780	Cable OPC-1194 [25W]	1
	8900010990	Cable OPC-1132 [50W]	1
W2	8900000730	Cable OPC-049	1
MP1	8010019151	2601 mobil bracket-1	1
MP2	8930059160	2601 felt	2
MP3	8820000530	Flange volt M4 × 8 NI	4
MP4	8810000470	Screw PH M5 × 12 (+-)	4
MP5	8810005840	Screw PH A M5 × 20	4
MP6	8850000150	Flat washer M5 NI BS	4
MP7	8850000390	Spring washer M5	4
MP8	8830000120	Nut M5	4
MP9	6910004210	731 mic hanger set	1
MP10	8310054770	1705 LCD seal (F)	1

**Screw abbreviations** A,BT: Self-tapping PH: Pan head  
 ZK: Black BS: Brass  
 NI: Nickel NI-ZU: Nickel-Zinc

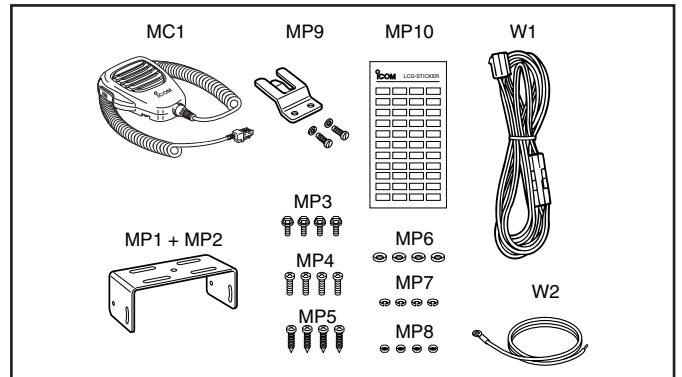

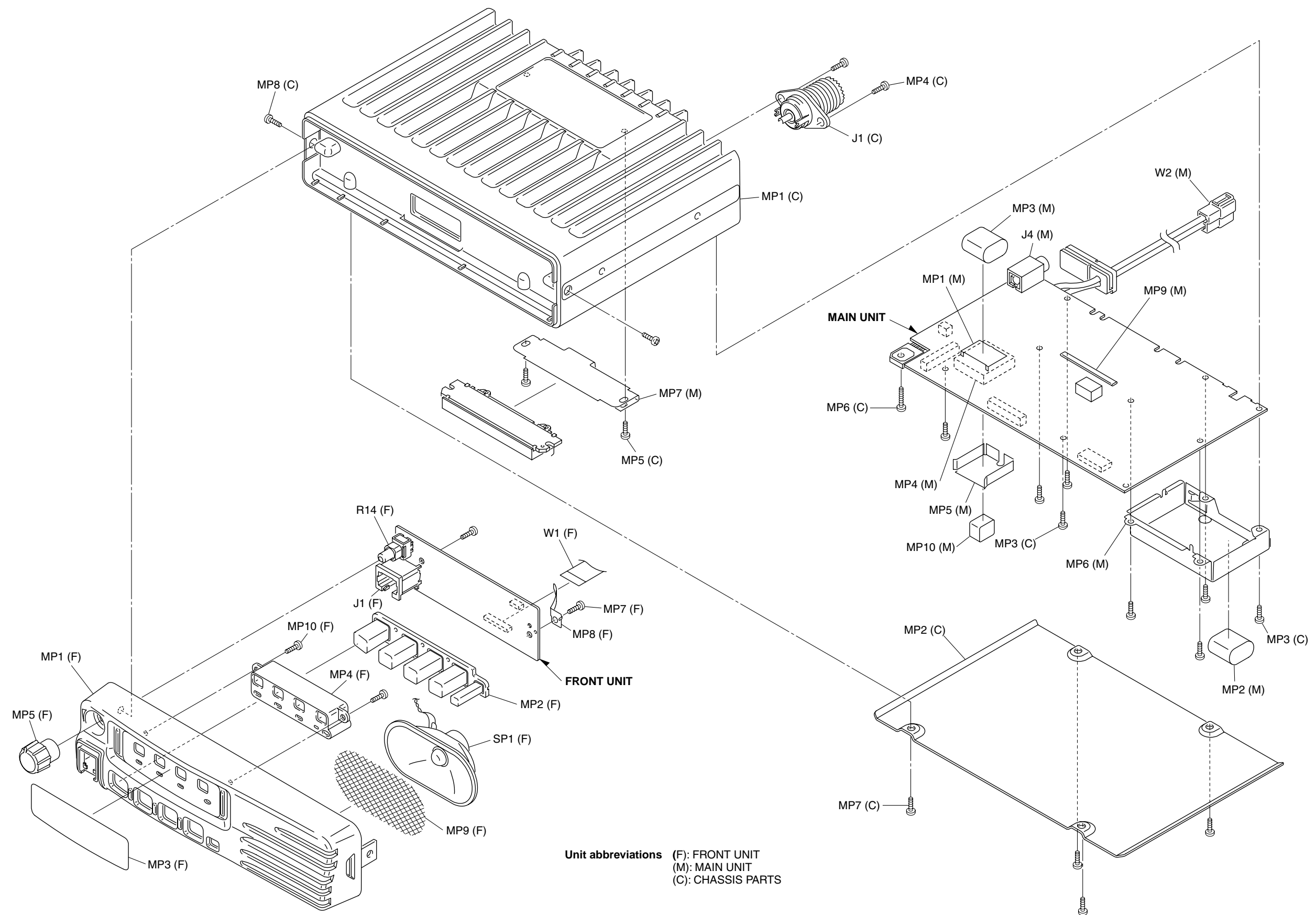







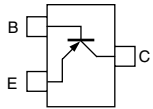
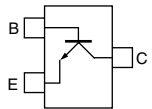
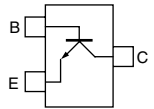
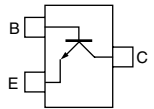
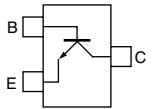
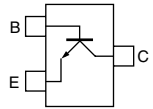
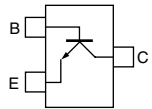
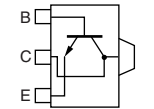
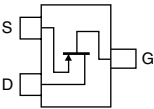
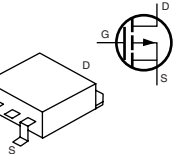
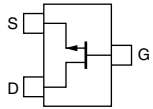
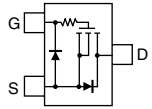
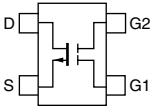
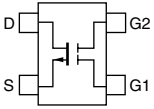
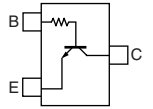
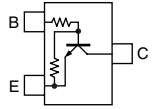
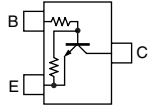
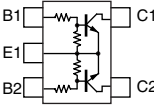
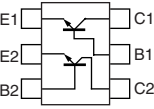

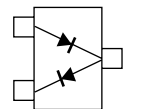

# SECTION 8 SEMI-CONDUCTOR INFORMATION

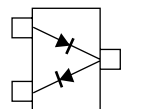
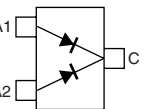
## • TRANSISTORS AND FET'S

<b>2SA1577 T106 Q</b> (Symbol: HQ) 	<b>2SC3356 T1B R25</b> (Symbol: R25) 	<b>2SC4081 T106 R</b> (Symbol: BR) 	<b>2SC4116 BL</b> (Symbol: LL) 	<b>2SC4215 O</b> (Symbol: QO) 
<b>2SC4226 T1 R25</b> (Symbol: R25) 	<b>2SC5107 O</b> (Symbol: MFO) 	<b>2SD1664 T100Q</b> (Symbol: DAQ) 	<b>2SJ144 GR</b> (Symbol: VG) 	<b>2SJ377</b> (Symbol: 4L) 
<b>2SK880 Y</b> (Symbol: XY) 	<b>2SK1829</b> (Symbol: K1) 	<b>3SK293</b> (Symbol: UF) 	<b>3SK299 T1 U73</b> (Symbol: U73) 	<b>DTC114TUA T106</b> (Symbol: 04) 
<b>DTC144EUA T106</b> (Symbol: 26) 	<b>DTC363 EK</b> (Symbol: H27) 	<b>XP1214</b> (Symbol: 9H) 	<b>XP6501 AB</b> (Symbol: 5N) 	

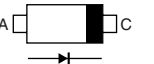
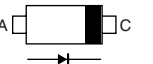
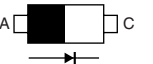
## • DIODES

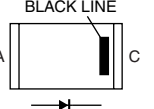
<b>1SS375-TL</b> (Symbol: FH) 	<b>1SV239</b> (Symbol: TC) 	<b>DA221 TL</b> (Symbol: K) 	<b>DAN222TL</b> (Symbol: N) 	<b>HVC350B</b> (Symbol: B0) 
<b>HVC362</b> (Symbol: V2) 	<b>HVC375B</b> (Symbol: B8) 	<b>HVC376B</b> (Symbol: B9) 	<b>MA2S111</b> (Symbol: A) 	<b>MA2S728</b> (Symbol: B) 
<b>MA77</b> (Symbol: 4B) 	<b>MA8056 M</b> (Symbol: 5-6) 	<b>UM9401F</b> (Symbol: none) 		

# SECTION 9 BOARD LAYOUTS

## 9-1 FRONT UNIT • TOP VIEW

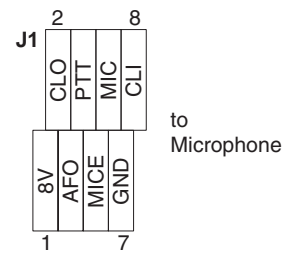
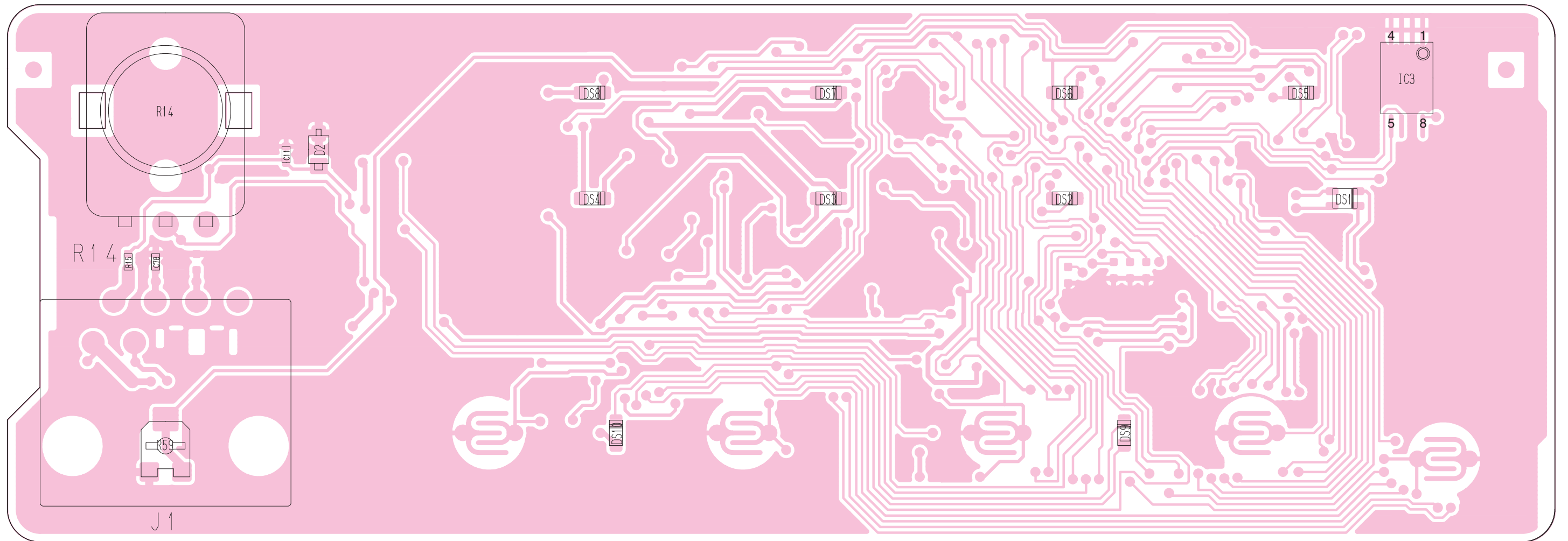

• BOTTOM VIEW (FRONT UNIT)

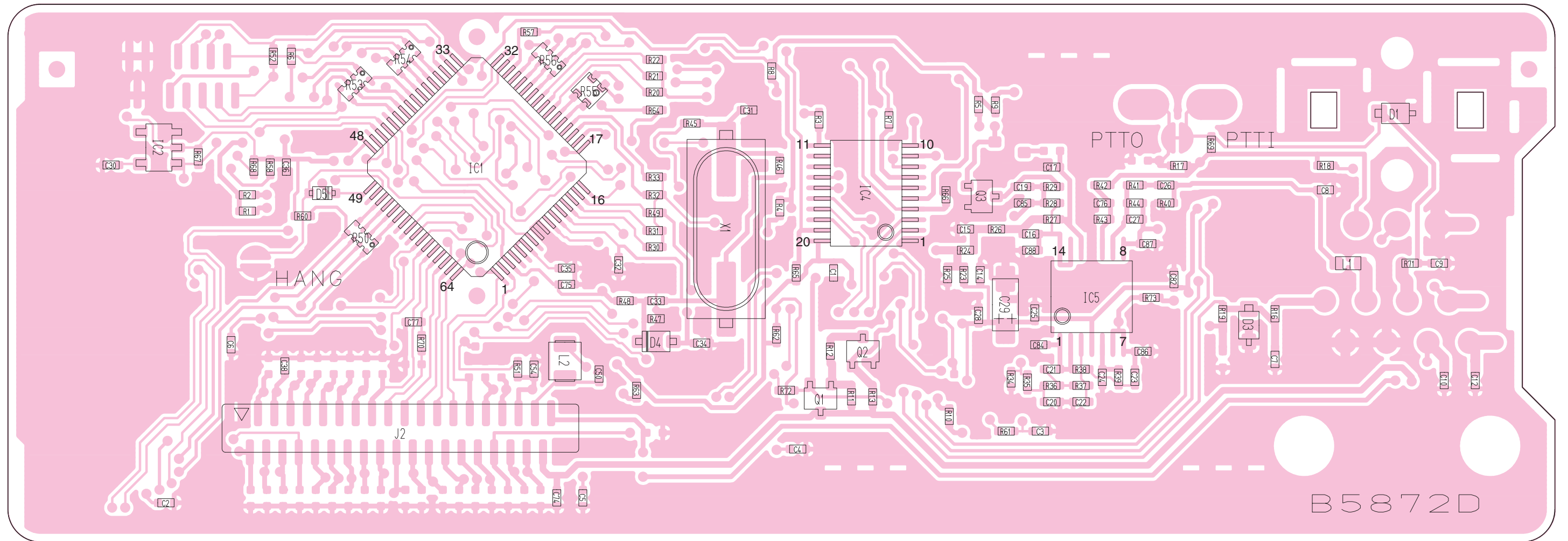

1	GND	39
2	DIM	GND
3	DAST	8V
4	RMUT	5V
5	NOIS	AFON
6	NWC	BEEP
7	TMUT	PWON
8	UNLK	CPU5
9	PLST	AFO
10	CDEC	
11	SCK	
12	SI	
13	SO	
14	CIRQ	
15	CCS	
16	MIC	
17	EPTT	
18	HORNO	
19	BEEP	
20	PWON	
21	8V	
22	GND	
23		
24		
25		
26		
27		
28		
29		
30		
31		
32		
33		
34		
35		
36		
37		
38		
39		

to MAIN unit J2

**9-2 MAIN UNIT**  
• TOP VIEW

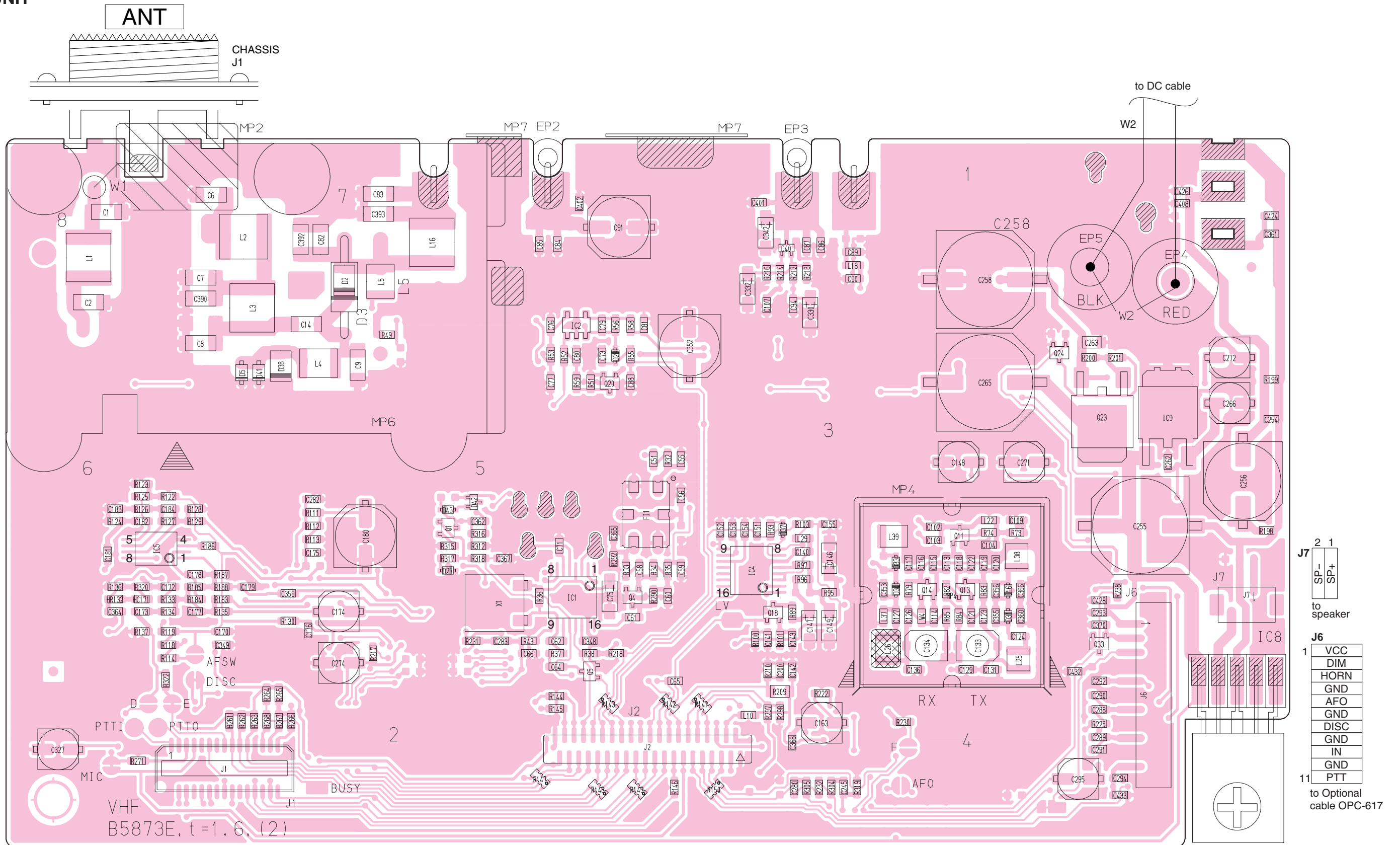

J1

1	PTTI	15	OPV1
2	PTTO	14	OPV2
3	MCOT	13	SCK
4	MCIN	12	
5	NC	11	
6	AFONO	10	
7	BEEPO	9	
8	BUSY	8	
9	NC	7	
10	NC	6	
11	SIGO	5	
12	DET	4	
13	DISC	3	
14	NC	2	
15	OPT1	1	
16	OPT2		
17	OPT3		
18	CCS		
19	CIRQ		
20	GND		
21	SO		
22	OPV3		
23	SI		
24	OPV2		
25	OPV1		
26	SCK		
27	OPV1		
28	OPV2		
29	OPV3		
30	GND		

to Optional unit

J2

40	GND	2	AFO
39	TONE	1	
38	TENC		
37	NOIS		
36	NWC		
35	TMUT		
34	UNLK		
33	PLST		
32	CDEC		
31	SCK		
30	SI		
29	SO		
28	OV12		
27	RSSI		
26	LVIN		
25	TEMP		
24	BATV		
23	RXC		
22	AFON		
21	BEEP		
20	PWON		
19	5V		
18	CPUS		
17	8V		
16	AFO		
15	GND		

to FRONT unit J2

J7

2	SP-	1	SP+
---	-----	---	-----

to speaker

J6

1	VCC
2	DIM
3	HORN
4	GND
5	AFO
6	GND
7	DISC
8	GND
9	IN
10	GND
11	PTT

to Optional cable OPC-617

• BOTTOM VIEW (MAIN UNIT)

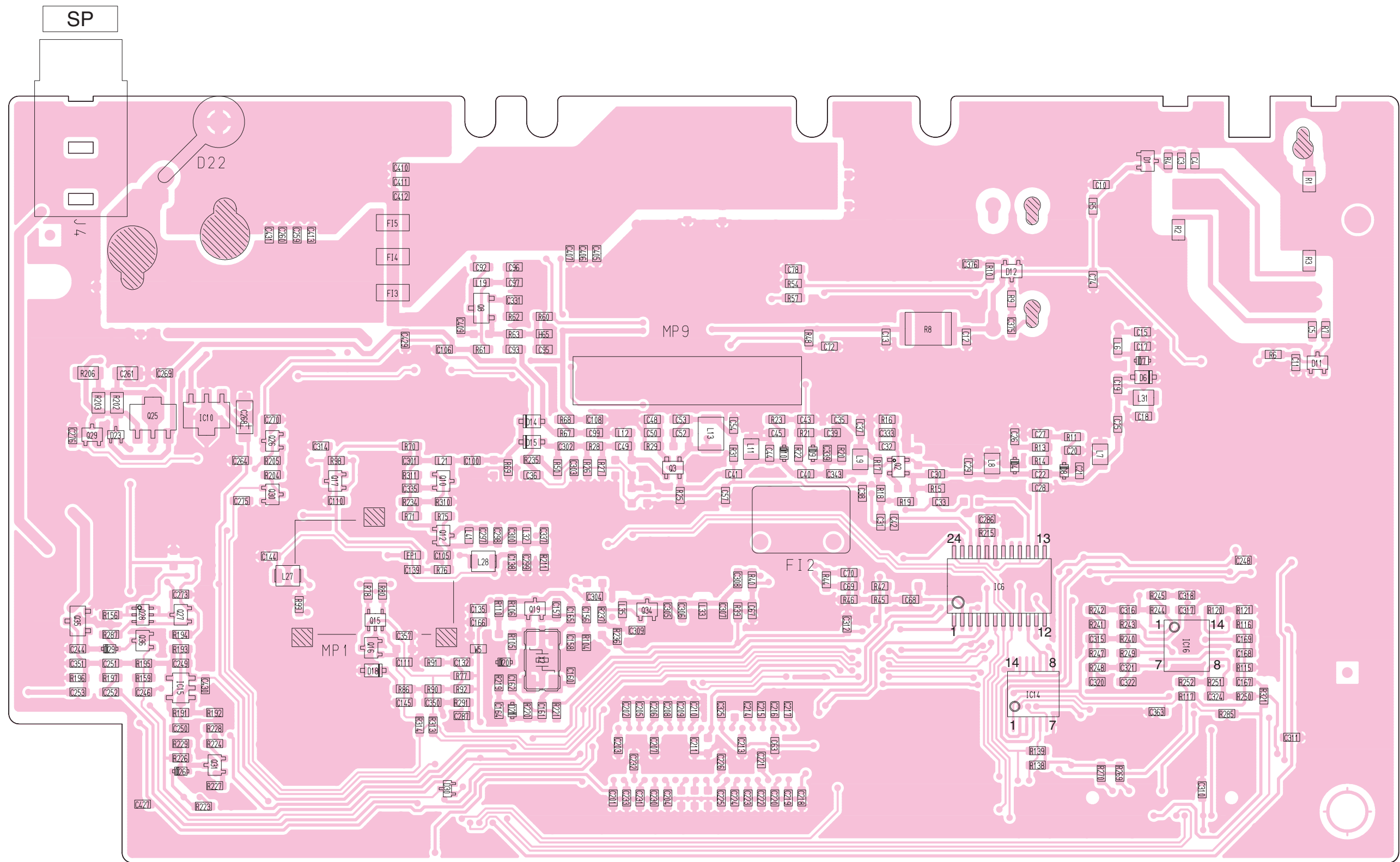

# SECTION 10 BLOCK DIAGRAM

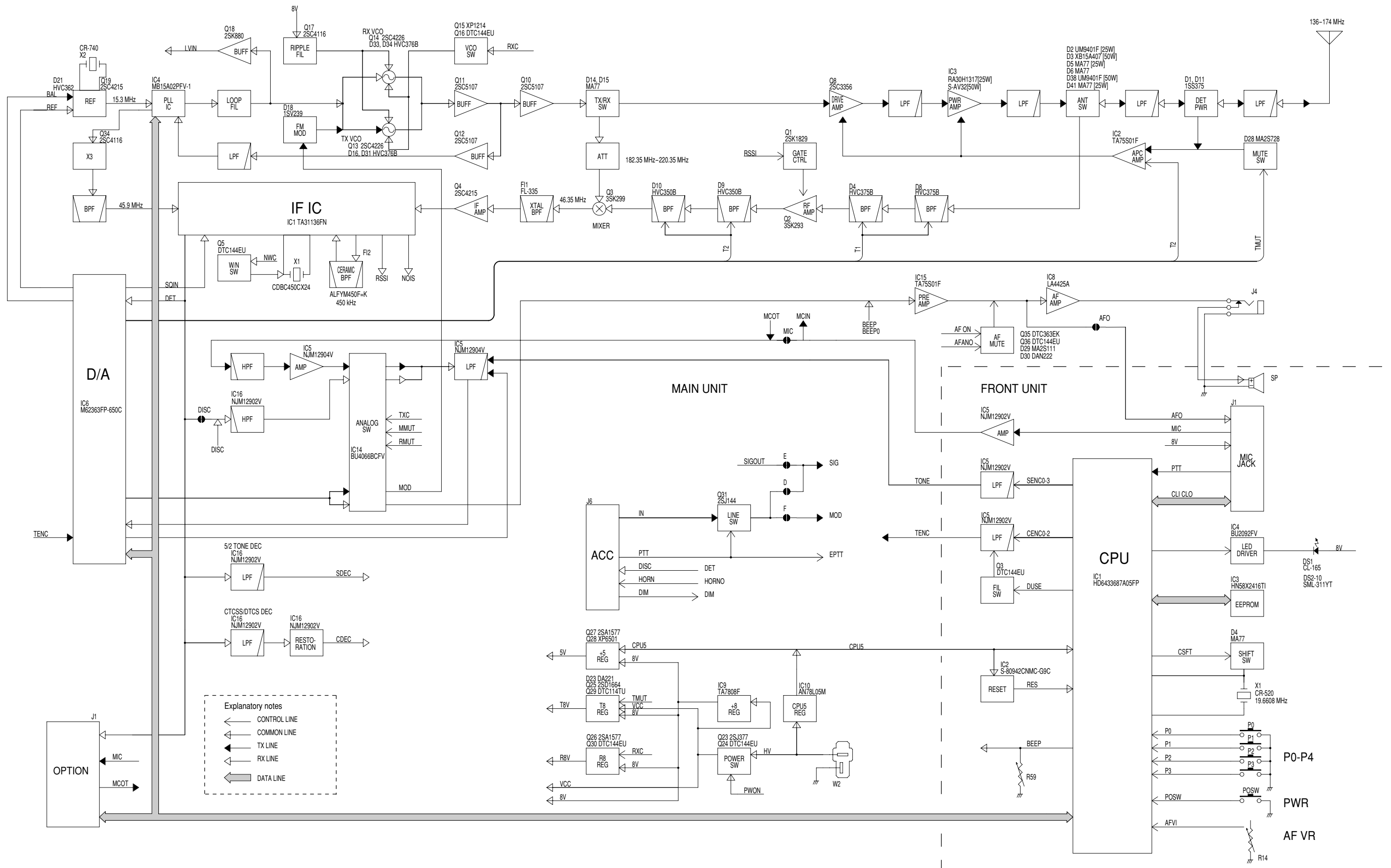

**Explanatory notes**

- ← CONTROL LINE
- ← COMMON LINE
- ← TX LINE
- ← RX LINE
- ← DATA LINE

# SECTION 11 VOLTAGE DIAGRAMS

## 11-1 FRONT UNIT

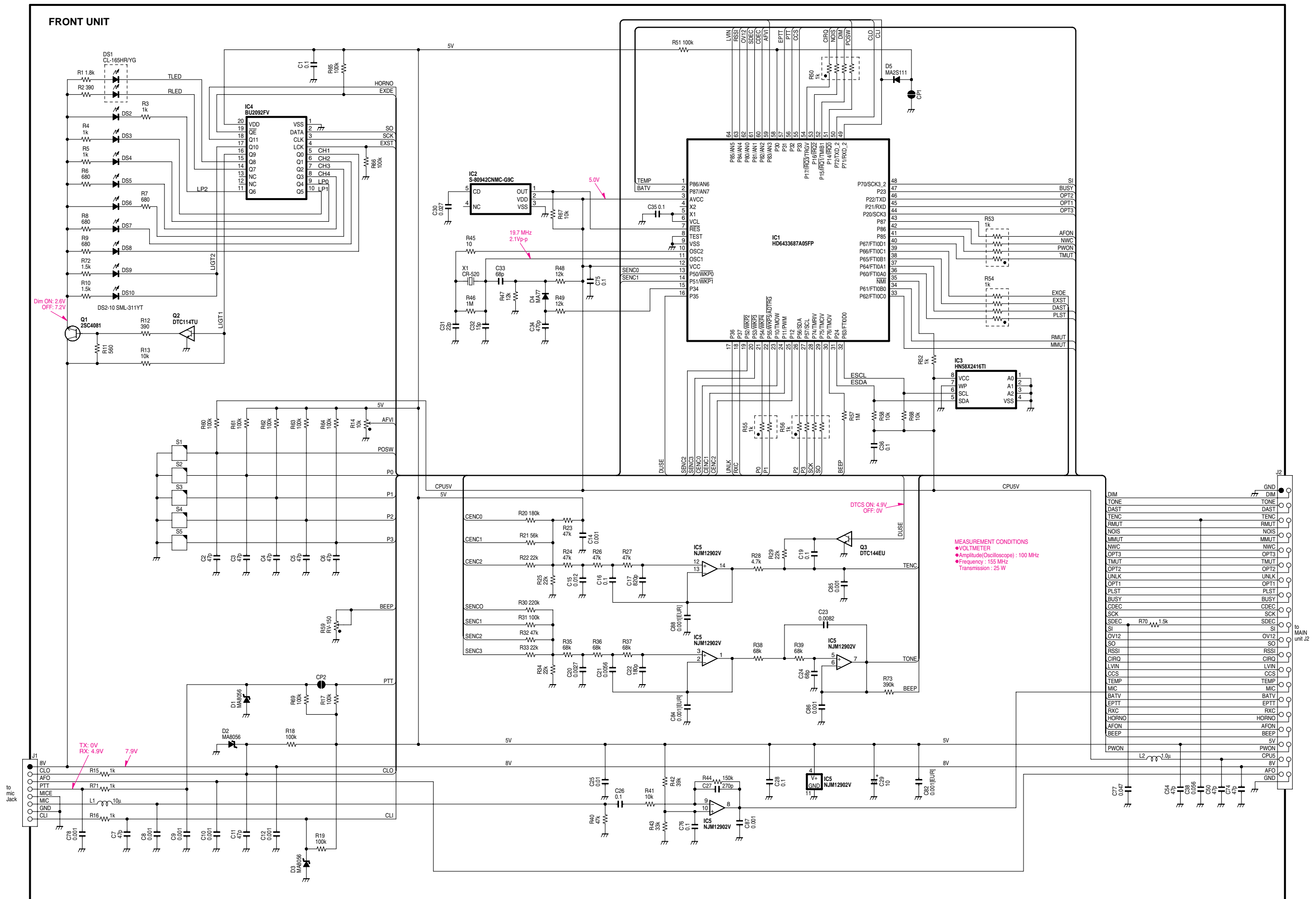

11-2 MAIN UNIT

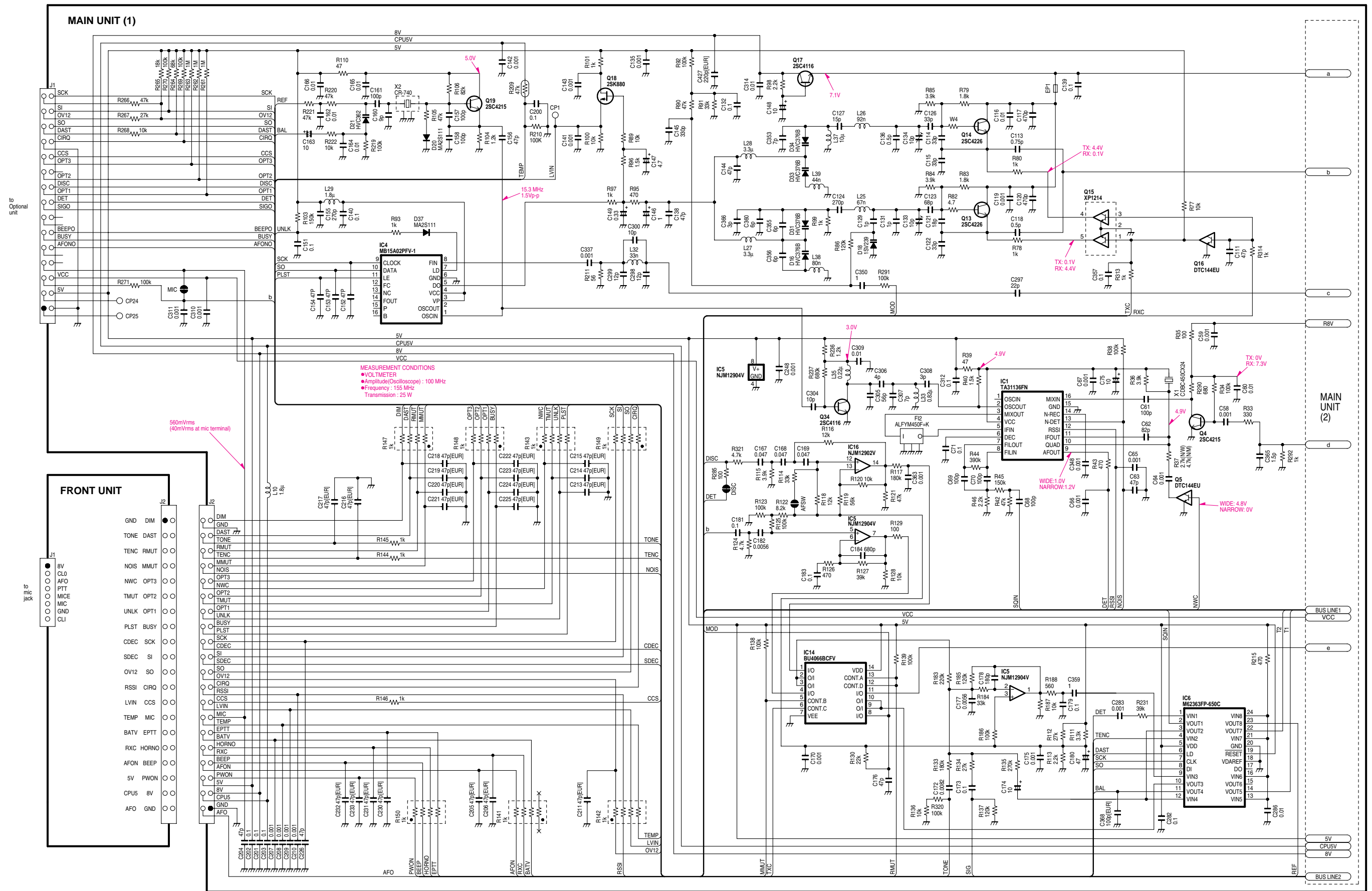



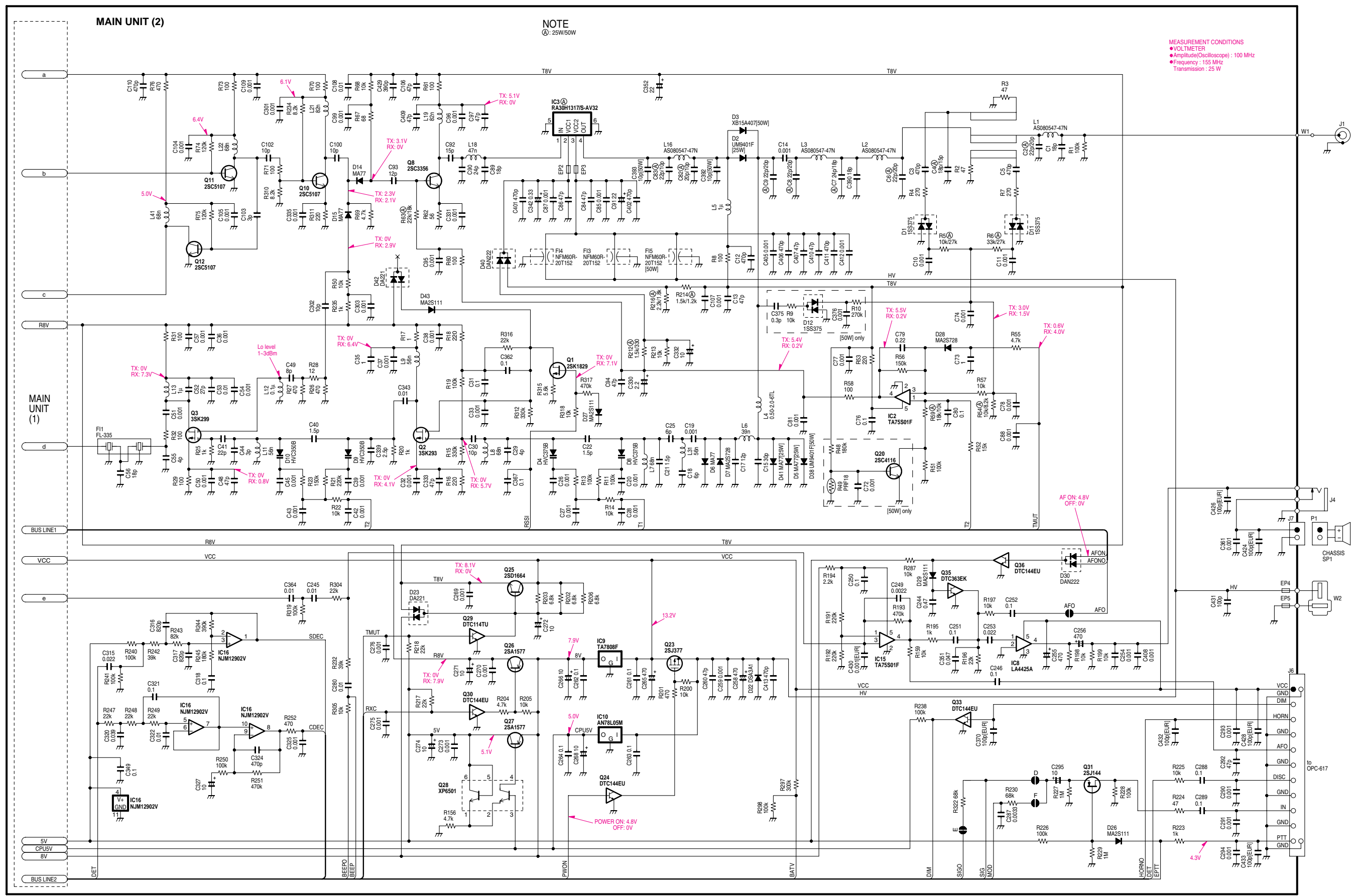

NOTE  
 ⓐ: 25W/50W

MEASUREMENT CONDITIONS  
 ● VOLTMETER  
 ● Amplitude(Oscilloscope) : 100 MHz  
 ● Frequency : 155 MHz  
 ● Transmission : 25 W

MAIN UNIT (2)

MAIN UNIT (1)

## Icom Inc.

1-1-32, Kamiminami, Hirano-ku, Osaka 547-0003, Japan  
Phone : +81 (06) 6793 5302  
Fax : +81 (06) 6793 0013  
URL : <http://www.icom.co.jp/world/index.html>

### Icom America Inc.

<Corporate Headquarters>  
2380 116th Avenue N.E., Bellevue, WA 98004, U.S.A.  
Phone : +1 (425) 454-8155 Fax : +1 (425) 454-1509  
URL : <http://www.icomamerica.com>  
E-mail : [sales@icomamerica.com](mailto:sales@icomamerica.com)  
<Customer Service>  
Phone : +1 (425) 454-7619

### Icom Canada

Glenwood Centre #150-6165  
Highway 17 Delta, B.C., V4K 5B8, Canada  
Phone : +1 (604) 952-4266 Fax : +1 (604) 952-0090  
URL : <http://www.icomcanada.com>  
E-mail : [info@icomcanada.com](mailto:info@icomcanada.com)

### Icom (Australia) Pty. Ltd.

Unit 1 / 103 Garden Road, Clayton VIC 3168 Australia  
Phone : +61 (03) 9549-7500 Fax : +61 (03) 9549-7505  
URL : <http://www.icom.net.au>  
E-mail : [sales@icom.net.au](mailto:sales@icom.net.au)

### Icom New Zealand

146A Harris Road, East Tamaki,  
Auckland, New Zealand  
Phone : +64 (09) 274 4062 Fax : +64 (09) 274 4708  
URL : <http://www.icom.co.nz>  
E-mail : [inquiries@icom.co.nz](mailto:inquiries@icom.co.nz)

### Beijing Icom Ltd.

10C07, Long silver Mansion, No.88, Yong Ding  
Road, Haidian District, Beijing, 100039, China  
Phone : +86 (010) 5889 5391/5392/5393  
Fax : +86 (010) 5889 5395  
E-mail : [bjicom@bjicom.com](mailto:bjicom@bjicom.com)  
URL : <http://www.bjicom.com>

### Icom (Europe) GmbH

Communication Equipment  
Himmelgeister Str. 100, D-40225 Düsseldorf, Germany  
Phone : +49 (0211) 346047 Fax : +49 (0211) 333639  
URL : <http://www.icomeurope.com>  
E-mail : [info@icomeurope.com](mailto:info@icomeurope.com)

### Icom Spain S.L

Ctra. Rubi, 88, 08190, Sant Cugat del Valles, Barcelona, SPAIN  
Phone : +34 (93) 590 26 70 Fax : +34 (93) 589 04 46  
URL : <http://www.icomspain.com>  
E-mail : [icom@icomspain.com](mailto:icom@icomspain.com)

### Icom (UK) Ltd.

Unit 9, Sea St., Herne Bay, Kent, CT6 8LD, U.K.  
Phone : +44 (01227) 741741 Fax : +44 (01227) 741742  
URL : <http://www.icomuk.co.uk>  
E-mail : [info@icomuk.co.uk](mailto:info@icomuk.co.uk)

### Icom France s.a.s.

Zac de la Plaine  
1 Rue Brindejonn des Moulinais BP 5804  
31505 Toulouse Cedex, France  
Phone : +33 (5) 61 36 03 03 Fax : +33 (5) 61 36 03 00  
URL : <http://www.icom-france.com>  
E-mail : [icom@icom-france.com](mailto:icom@icom-france.com)

### Asia Icom Inc.

6F No.68, Sec. 1 Cheng-Teh Road, Taipei, Taiwan, R.O.C.  
Phone : +886 (02) 2559 1899 Fax : +886 (02) 2559 1874  
URL : <http://www.asia-icom.com>  
E-mail : [sales@asia-icom.com](mailto:sales@asia-icom.com)

### Icom Polska

Sopot, 3 Maja 54 Poland  
Phone : +48 (58) 550 7135 Fax : +48 (58) 551 0484  
E-mail : [icompolska@icompolska.com.pl](mailto:icompolska@icompolska.com.pl)

**Count on us!**

**Icom Inc.**

1-1-32, Kamiminami, Hirano-ku, Osaka 547-0003, Japan

S-13906HZ-C1VS-④

© 2003 Icom Inc.